

MACHOS Y TERRAJAS



EL REY DE LOS FLUIDOS DE CORTE DE INGENIERÍA (Nº 1 EN U.S.A.)

PARA TODA CLASE DE MATERIALES

EP-XTRA

Tap Magic[®]

DISPONIBLE HOJA TÉCNICA
Y DE SEGURIDAD E HIGIENE

USO
GENERAL

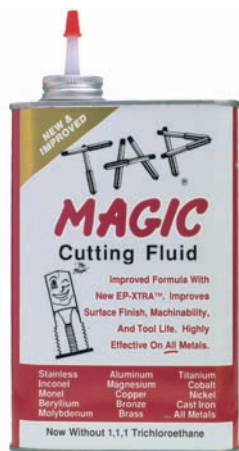

Ref. **TM10012**

			EP-XTRA
	UNIDAD DE EMBALAJE	€	
			
TM10004	0,120 l.	1 Lata	7,08
TM10012	0,360 l.	1 Aerosol	30,19
TM10016	0,473 l.	1 Lata	22,58
TM10128	3,780 l.	1 Lata	137,09
TM10640	19,000 l.	1 Lata	595,08

* Ponemos a su disposición cajas de latas con la siguientes cantidades:

- 0,120 l. - 24 latas por caja.
- 0,360 l. - 12 aerosoles por caja.
- 0,473 l. - 12 latas por caja.



EXCLUSIVO PARA ALUMINIO Y MAGNESIO

ALUMINIO

Tap Magic[®]

DISPONIBLE HOJA TÉCNICA
Y DE SEGURIDAD E HIGIENE

Al



Ref. **TM20012**

			ALUMINIO
	UNIDAD DE EMBALAJE	€	
			
TM20004	0,120 l.	1 Lata	7,15
TM20012	0,360 l.	1 Aerosol	31,05
TM20016	0,473 l.	1 Lata	22,58
TM20128	3,780 l.	1 Lata	136,68
TM20640	19,000 l.	1 Lata	595,08

* Ponemos a su disposición cajas de latas con la siguientes cantidades:

- 0,120 l. - 24 latas por caja.
- 0,360 l. - 12 aerosoles por caja.
- 0,473 l. - 12 latas por caja.

EL REY DE LOS FLUIDOS DE CORTE DE INGENIERÍA (Nº 1 EN U.S.A.)

ECOLÓGICO BIODEGRADABLE PARA TODA CLASE DE MATERIALES

DISPONIBLE HOJA TÉCNICA Y DE SEGURIDAD E HIGIENE

PRO-TAP



Ref. **TM30012**

Tap Magic

			PRO-TAP
	UNIDAD DE EMBALAJE		€
TM30004	0,120 l.	1 Lata	7,02
TM30012	0,360 l.	1 Aerosol	30,91
TM30016	0,473 l.	1 Lata	22,51
TM30128	3,780 l.	1 Lata	136,36
TM30640	19,000 l.	1 Lata	593,64

* Ponemos a su disposición cajas de latas con la siguientes cantidades:

- 0,120 l. - 24 latas por caja.
- 0,360 l. - 12 aerosoles por caja.
- 0,473 l. - 12 latas por caja.

EN ESPUMA. ¡MÁXIMA ADHERENCIA A LA HERRAMIENTA! PARA TODA CLASE DE MATERIALES

XTRA-FOAMY

DISPONIBLE HOJA TÉCNICA Y DE SEGURIDAD E HIGIENE



Ref. **TM80017**

			XTRA-FOAMY
	UNIDAD DE EMBALAJE		€
TM80017	0,500 l.	1 Lata	47,88

* Ponemos a su disposición cajas de latas con la siguientes cantidades:

- 0,500 l. - 12 aerosoles por caja.

ULTRA VISCOSO, PARA MATERIALES EXTREMADAMENTE DUROS HASTA 45 HRc

XTRA-THICK

DISPONIBLE HOJA TÉCNICA Y DE SEGURIDAD E HIGIENE



Ref. **TM70016**

			XTRA-THICK
	UNIDAD DE EMBALAJE		€
TM70016	0,473 l.	1 Lata	27,91
TM70128	3,780 l.	1 Lata	165,89
TM70640	19,000 l.	1 Lata	691,82

* Ponemos a su disposición cajas de latas con la siguientes cantidades:

- 0,120 l. - 24 latas por caja.
- 0,360 l. - 12 aerosoles por caja.
- 0,473 l. - 12 latas por caja.

* Adherencia por más tiempo a la herramienta.

* Rendimientos extremos en los materiales más duros, hasta de 45 HRc.

* Ideal para Inconel, Titanio, Inoxidables y materiales endurecidos.

JUEGOS DE MACHOS Y TERRAJAS PARA ROSCAR A MANO HSS

Machos y Terrajas
Verde

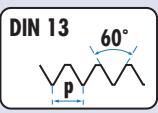

Ref. **MO** HSS DIN 352 DIN 2181 TOL 6H

Ref. **C5** HSS DIN 223 TOL 6g



		MO				C5	
	Ud s	\varnothing	L ₁ x L ₂ x \square mm	€	\varnothing x L ₃ mm	€	
M 1x0,20	2	0,80	32 x 5,5 x 2,1	68,47			
M 1x0,25	3	0,75	32 x 6,0 x 2,1	68,47	16 x 5	74,62	
M 1,1x0,20	2	0,90	32 x 5,5 x 2,1	68,47			
M 1,1x0,25	3	0,85	32 x 6,0 x 2,1	68,47	16 x 5	71,72	
M 1,2x0,20	2	1,00	32 x 5,5 x 2,1	68,47			
M 1,2x0,25	3	0,95	32 x 6,0 x 2,1	68,47	16 x 5	67,29	
M 1,4x0,20	2	1,20	32 x 7,0 x 2,1	68,47			
M 1,4x0,25	2	1,15	32 x 7,0 x 2,1	68,47			
M 1,4x0,30	3	1,10	32 x 7,0 x 2,1	68,47	16 x 5	61,67	
M 1,6x0,20	2	1,40	32 x 8,0 x 2,1	62,47			
M 1,6x0,25	2	1,35	32 x 8,0 x 2,1	62,47			
M 1,6x0,35	3	1,25	32 x 8,0 x 2,1	62,47	16 x 5	58,26	
M 1,7x0,35	3	1,35	32 x 8,0 x 2,1	58,63	16 x 5	58,26	
M 1,8x0,20	2	1,60	32 x 8,0 x 2,1	58,63			
M 1,8x0,25	2	1,55	32 x 8,0 x 2,1	58,63			
M 1,8x0,35	3	1,45	32 x 8,0 x 2,1	58,63	16 x 5	58,26	
M 2x0,25	2	1,75	36 x 8,0 x 2,1	58,63			
M 2x0,35	2	1,65	36 x 8,0 x 2,1	58,63			
M 2x0,40	3	1,60	36 x 9,0 x 2,1	29,98*	20 x 5	23,39*	
M 2,2x0,45	3	1,75	36 x 9,0 x 2,1	33,39	20 x 5	50,01	
M 2,3x0,40	3	1,90	36 x 9,0 x 2,1	30,81	16 x 5	26,63	
M 2,5x0,45	3	2,05	40 x 9,0 x 2,1	30,16	20 x 5	23,39	
M 2,6x0,45	3	2,10	40 x 9,0 x 2,1	29,95	25 x 9	24,48	
M 3x0,35	2	2,65	40 x 9,0 x 2,7	38,29	20 x 5	37,03	
M 3x0,50	3	2,50	40 x 11,0 x 2,7	16,83*	25 x 9	21,47*	
M 3x0,60	3	2,40	45 x 13,0 x 3,0	33,57	20 x 5	30,13	
M 3,5x0,60	3	2,90	45 x 13,0 x 3,0	20,17	25 x 9	22,46	
M 3,5x0,75	3	2,75	45 x 18,0 x 3,0	36,46	25 x 9	50,51	
M 4x0,50	2	3,50	45 x 13,0 x 3,4	33,75	20 x 5	23,90	
M 4x0,70	3	3,30	45 x 13,0 x 3,4	16,81*	25 x 9	21,47*	
M 4x0,75	3	3,25	45 x 13,0 x 3,4	27,30	20 x 7	34,22	
M 4x0,80	3	3,20	45 x 13,0 x 3,4	107,93	20 x 7	77,88	
M 4,5x0,50	2	4,00	50 x 12,0 x 4,9	32,10	25 x 9	33,59	
M 4,5x0,75	3	3,75	50 x 16,0 x 4,9	30,13	20 x 7	24,30	
M 5x0,50	2	4,50	50 x 12,0 x 4,9	33,76	20 x 5	25,85	
M 5x0,75	2	4,25	50 x 14,0 x 4,9	32,71	20 x 7	34,40	
M 5x0,80	3	4,20	50 x 16,0 x 4,9	17,64*	25 x 9	21,87*	
M 5x0,90	3	4,10	50 x 16,0 x 4,9	31,17	25 x 9	34,40	
M 5x1,00	3	4,00	50 x 16,0 x 4,9	113,97	25 x 9	75,78	

		MO			C5	
	Ud s	\varnothing	L ₁ x L ₂ x \square mm	€	\varnothing x L ₃ mm	€
M 5,5x0,90	3	4,60	50 x 16 x 4,9	113,97	25 x 9	79,75
M 6x0,50	2	5,50	50 x 14 x 4,9	24,22	20 x 5	29,98
M 6x0,75	2	5,25	50 x 14 x 4,9	20,39	25 x 9	23,69
M 6x1,00	3	5,00	50 x 19 x 4,9	17,64*	25 x 9	21,47*
M 6x1,25	3	4,75	50 x 19 x 4,9	113,97	25 x 9	77,88
M 7x0,75	2	6,25	50 x 14 x 4,9	24,95	25 x 9	25,36
M 7x1,00	3	6,00	50 x 19 x 4,9	21,68*	25 x 9	22,95*
M 7x1,25	3	5,75	50 x 19 x 4,9	129,91	25 x 9	93,59
M 8x0,50	2	7,50	50 x 16 x 4,9	39,73	25 x 9	36,00
M 8x0,75	2	7,25	50 x 16 x 4,9	28,06	25 x 9	25,36
M 8x1,00	2	7,00	56 x 18 x 4,9	20,00*	25 x 9	24,45*
M 8x1,25	3	6,75	56 x 22 x 4,9	21,66*	25 x 9	22,78*
M 8x1,50	3	6,50	56 x 22 x 4,9	126,37	25 x 9	85,32
M 9x1,00	2	8,00	63 x 18 x 5,5	27,71	25 x 9	27,17
M 9x1,25	3	7,80	63 x 22 x 5,5	36,01*	25 x 9	25,99*
M 10x0,50	2	9,50	63 x 18 x 5,5	43,32	38 x 10	94,27
M 10x0,75	2	9,25	63 x 18 x 5,5	41,90	30 x 11	45,04
M 10x1,00	2	9,00	63 x 18 x 5,5	21,42	38 x 10	29,87
M 10x1,25	2	8,80	70 x 24 x 5,5	21,71	38 x 10	30,69
M 10x1,50	3	8,50	70 x 24 x 5,5	26,46*	38 x 10	28,83*
M 11x0,75	2	10,25	63 x 18 x 6,2	106,68	30 x 11	92,71
M 11x1,00	2	10,00	63 x 18 x 6,2	39,82	30 x 11	48,50
M 11x1,25	2	9,75	63 x 20 x 6,2	39,82	30 x 11	47,12
M 11x1,50	3	9,50	70 x 24 x 6,2	45,39	38 x 10	34,93
M 12x0,75	2	11,25	70 x 20 x 7,0	56,39	38 x 10	51,09
M 12x1,00	2	11,00	70 x 20 x 7,0	38,16	38 x 10	41,79
M 12x1,25	2	10,75	70 x 20 x 7,0	37,50	38 x 10	40,29
M 12x1,50	2	10,50	70 x 20 x 7,0	31,96*	38 x 10	38,94*
M 12x1,75	3	10,20	75 x 29 x 7,0	37,24*	38 x 14	34,74*
M 13x0,75	2	12,25	70 x 20 x 9,0	106,68	38 x 10	92,72
M 13x1,00	2	12,00	70 x 20 x 9,0	59,71	38 x 10	51,26
M 13x1,25	2	11,75	70 x 20 x 9,0	56,01	38 x 10	59,38
M 13x1,50	2	11,50	70 x 20 x 9,0	56,01	38 x 10	53,89
M 13x1,75	3	11,25	70 x 20 x 9,0	69,28	38 x 14	53,89
M 14x0,75	2	13,25	70 x 20 x 9,0	106,68	38 x 10	86,93
M 14x1,00	2	13,00	70 x 20 x 9,0	56,00	38 x 10	45,61
M 14x1,25	2	12,80	70 x 20 x 9,0	45,80*	38 x 10	45,61*
M 14x1,50	2	12,50	70 x 20 x 9,0	35,96	38 x 10	40,29
M 14x1,75	2	12,25	70 x 20 x 9,0	137,30	38 x 14	137,38
M 14x2,00	3	12,00	80 x 30 x 9,0	42,00*	38 x 14	34,74*
M 15x1,00	2	14,00	70 x 20 x 9,0	80,62	45 x 14	58,27
M 15x1,25	2	13,75	70 x 20 x 9,0	85,94	45 x 14	81,14
M 15x1,50	2	13,50	70 x 20 x 9,0	73,38	45 x 14	58,27
M 15x2,00	3	13,00	80 x 30 x 9,0	85,60	45 x 14	73,04
M 16x1,00	2	15,00	70 x 20 x 9,0	76,34	45 x 14	60,42
M 16x1,25	2	14,75	70 x 20 x 9,0	80,35	45 x 14	54,99
M 16x1,50	2	14,50	70 x 20 x 9,0	44,74*	45 x 14	45,33*
M 16x2,00	3	14,00	80 x 32 x 9,0	59,01	45 x 18	48,03
M 17x1,00	2	16,00	70 x 20 x 9,0	126,84	45 x 14	86,46
M 17x1,25	2	15,75	70 x 20 x 9,0	126,84	45 x 14	86,46
M 17x1,50	2	15,50	70 x 20 x 9,0	126,84	45 x 14	86,46
M 18x1,00	2	17,00	80 x 22 x 11	84,86	45 x 14	60,42
M 18x1,25	2	16,75	80 x 22 x 11	117,90	45 x 14	71,88

* Disponibles también con rosca izquierda con 100% de recargo sobre los precios tarifados en rosca derecha
* Recargo por cojinetes abiertos 20% sobre los precios tarifados

JUEGOS DE MACHOS Y TERRAJAS PARA ROSCAR A MANO HSS

BSW

Ref. **MO** **HSS** **DIN 351** **TOL Clase 2**

BSF

Ref. **MO** **HSS** **DIN 5157** **TOL ISO 228**

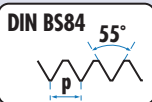

Ref. **C5** **HSS** **DIN 223**

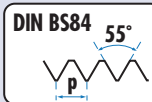

Ref. **C5** **HSS** **DIN 223**

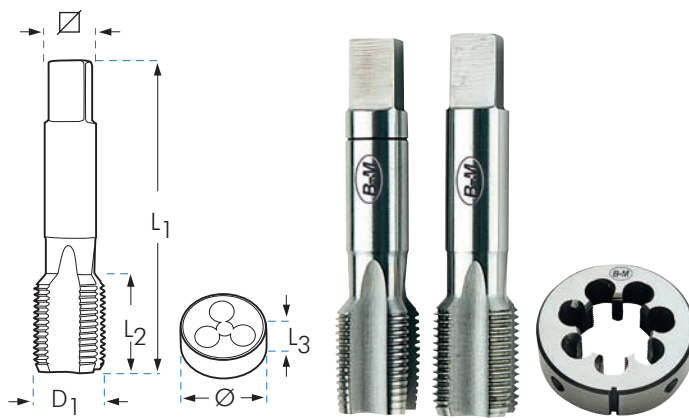

Ud	D ₁ mm	MO				C5	
		Ud	D ₁ mm	L ₁ x L ₂ x L ₃ mm	€	Ø x L ₃ mm	€
W 1/16-60h.	3	1,59	1,15	32x 8x 2,1	44,17	16x 5	59,45
W 3/32-48h.	3	2,38	1,80	40x 9x 2,1	33,08	20x 5	30,10
W 1/8-40h.	3	3,17	2,55	40x14x 2,7	22,98*	25x 9	23,76*
W 5/32-32h.	3	3,97	3,10	45x17x 3,4	23,22	25x 9	23,34
W 3/16-24h.	3	4,76	3,60	50x19x 4,9	22,98	25x 9	23,76
W 7/32-24h.	3	5,55	4,40	50x19x 4,9	37,80	25x 9	31,03
W 1/4-20h.	3	6,35	5,10	50x20x 4,9	25,89*	25x 9	23,34*
W 5/16-18h.	3	7,94	6,50	56x20x 4,9	31,61*	25x 9	24,35*
W 3/8-16h.	3	9,52	7,90	63x22x 5,5	34,74*	38x10	35,22*
W 7/16-14h.	3	11,11	9,25	70x22x 6,2	46,63	38x10	35,28
W 1/2-12h.	3	12,70	10,50	75x25x 7,0	50,04	38x14	35,94
W 9/16-12h.	3	14,29	12,00	80x26x 9,0	68,07	38x14	42,27
W 5/8-11h.	3	15,87	13,40	80x27x 9,0	78,27*	45x18	52,21*
W 11/16-11h.	3	17,46	15,25	95x32x11,0	177,63	45x18	82,80
W 3/4-10h.	3	19,05	16,50	95x32x11,0	111,42*	45x18	52,28*
W 7/8-9h.	3	22,22	19,25	100x32x14,5	150,76*	55x22	76,88*
W 1"-8h.	3	25,40	21,75	110x36x14,5	184,76*	55x22	77,57*
W 1.1/8-7h.	3	28,57	24,75	125x40x18,0	273,84	65x25	122,15
W 1.1/4-7h.	3	31,75	27,75	125x40x18,0	331,32	65x25	122,20
W 1.3/8-6h.	3	34,92	30,50	150x50x22,0	412,02	65x25	124,45
W 1.1/2-6h.	3	38,10	33,50	150x50x24,0	496,05	75x30	189,18
W 1.5/8-5h.	3	41,27	46,50	150x56x24,0	664,88	75x30	226,84
W 1.3/4-5h.	3	44,45	39,00	160x58x29,0	818,32	90x36	285,49
W 1.7/8-4,5h.	3	47,62	42,00	180x65x29,0	1.056,91	90x36	312,37
W 2"-4,5h.	3	50,80	44,50	180x65x32,0	1.109,56	90x36	327,38
W 2.1/4-4h.	3	57,15	50,00	200x85x35,0	1.967,20	105x36	
W 2.1/2-4h.	3	63,50	56,50	220x85x39,0	2.393,13	120x36	
W 2.3/4-3,5h.	3	69,85	62,00	250x90x44,0	3.417,10	120x36	
W 3"-3,5h.	3	76,20	68,00	250x90x44,0	3.953,21	140x36	

Ud	D ₁ mm	MO				C5	
		Ud	D ₁ mm	L ₁ x L ₂ x L ₃ mm	€	Ø x L ₃ mm	€
3/16-32h.	2	4,76	4,0	50x19x 4,9	85,67	20x 7	30,10
1/4-26h.	2	6,35	5,2	50x20x 4,9	34,85	20x 7	33,34
5/16-22h.	2	7,94	6,6	56x20x 4,9	40,64	25x 9	33,71
3/8-20h.	2	9,52	8,1	63x22x 5,5	47,01	30x11	64,76
7/16-18h.	2	11,11	9,5	70x22x 6,2	56,42	30x11	64,16
1/2-16h.	2	12,70	11,0	75x25x 7,0	63,83	38x10	55,99
9/16-16h.	2	14,29	12,5	80x26x 9,0	76,51	38x10	59,08
5/8-14h.	2	15,88	14,0	80x26x 9,0	100,12	45x14	92,11
3/4-12h.	2	19,05	16,5	95x33x11,0	153,05	45x14	92,96
7/8-11h.	2	22,23	19,5	100x33x14,5	182,67	55x22	124,66
1"-10h.	2	25,40	22,5	110x40x14,5	256,41	55x22	123,29
1.1/8-9h.	2	28,57	25,5	110x40x16,0	578,57		
1.1/4-9h.	2	31,75	28,5	125x46x18,0	660,55		
1.1/2-8h.	2	38,10	34,5	150x55x22,0	1.006,71		

* Disponibles también con rosca izquierda con 100% de recargo sobre los precios tarifados en rosca derecha

JUEGOS DE MACHOS Y TERRAJAS PARA ROSCAR A MANO HSS

**BSP
(GAS)**

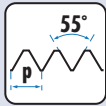

Ref. **M0** **HSS** **DIN 5157** **TOL ISO 228**

Ref. **C5** **HSS** **DIN 223**



Icon	Ud s	D ₁ mm	Ø	L ₁ x L ₂ x \square mm	M0		C5	
					€	Ø x L ₃ mm	€	
G 1/8-28h.	2	9,73	8,80	63 x 20 x 5,5	26,87*	38 x 10	37,75*	
G 1/4-19h.	2	13,16	11,80	70 x 22 x 9,0	37,86*	38 x 10	37,54*	
G 3/8-19h.	2	16,66	15,25	70 x 22 x 9,0	47,52*	45 x 14	49,73*	
G 1/2-14h.	2	20,95	19,00	80 x 22 x 12,0	66,66*	45 x 14	49,73*	
G 5/8-14h.	2	22,91	21,00	80 x 22 x 14,5	86,11*	55 x 16	68,98*	
G 3/4-14h.	2	26,44	24,50	90 x 22 x 16,0	104,05*	55 x 16	83,33*	
G 7/8-14h.	2	30,20	28,25	90 x 22 x 18,0	140,08	65 x 18	106,90	
G 1"-11h.	2	33,25	30,75	100 x 25 x 20,0	166,54*	65 x 18	107,93*	
G 1.1/8-11h.	2	37,90	35,50	125 x 40 x 22,0	251,40	75 x 20	152,33	
G 1.1/4-11h.	2	41,91	39,50	125 x 40 x 24,0	273,96*	75 x 20	149,53*	
G 1.3/8-11h.	2	44,32	42,00	125 x 40 x 29,0	372,10	90 x 22	240,77	
G 1.1/2-11h.	2	47,80	45,25	140 x 40 x 29,0	414,04	90 x 22	231,93	
G 1.3/4-11h.	2	53,75	51,25	140 x 40 x 32,0	688,32	105 x 22	240,77	
G 2"-11h.	2	59,61	57,00	160 x 40 x 35,0	765,36	105 x 22	289,77	
G 2.1/4-11h.	2	65,71	63,00	160 x 40 x 39,0	1.311,12	105 x 22		
G 2.1/2-11h.	2	75,18	72,50	160 x 40 x 39,0	1.970,77	120 x 22		
G 2.3/4-11h.	2	81,53	79,00	160 x 40 x 39,0	2.389,75	135 x 22		
G 3"-11h.	2	87,88	85,50	160 x 40 x 39,0	2.487,23	130 x 25		
G 4"-11h.	2	113,03	110,50	180 x 45 x 44,0	3.772,29			

* Disponibles también con rosca izquierda con 100% de recargo sobre los precios tarifados en rosca derecha

JUEGOS DE MACHOS Y TERRAJAS PARA ROSCAR A MANO HSS

UNC

Ref. **M0** **HSS** **DIN 351** **TOL 2B**

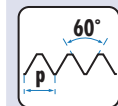

Ref. **C5** **HSS** **DIN 223** **TOL 2a**

UNF

Ref. **M0** **HSS** **DIN 2181** **TOL 2B**

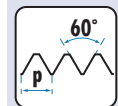

Ref. **C5** **HSS** **DIN 223** **TOL 2a**

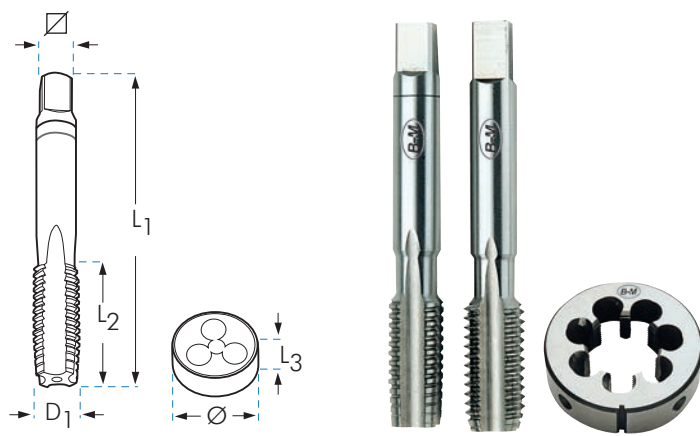

Ud	D1 mm	L1 x L2 x L3 mm	M0		C5	
			€	Ø x L3 mm	€	
UNC n° 1-64h.	3	1,85 1,50 36x 8x 2,1	76,64	16x 5		
UNC n° 2-56h.	3	2,18 1,80 36x 9x 2,1	54,16	16x 5		
UNC n° 3-48h.	3	2,51 2,10 40x 9x 2,1	54,16	16x 5		
UNC n° 4-40h.	3	2,84 2,25 40x11x 2,7	42,59	20x 5	31,60	
UNC n° 5-40h.	3	3,17 2,60 40x11x 2,7	40,72	20x 5	31,69	
UNC n° 6-32h.	3	3,50 2,75 45x13x 3,0	40,72	20x 7	31,69	
UNC n° 8-32h.	3	4,17 3,50 45x13x 3,4	40,72	20x 7	31,69	
UNC n°10-24h.	3	4,83 3,90 50x16x 4,9	40,72	20x 7	31,69	
UNC n°12-24h.	3	5,49 4,50 50x19x 4,9	40,72	20x 7	31,69	
UNC 1/4-20h.	3	6,35 5,10 50x19x 4,9	34,90*	20x 7	29,87*	
UNC 5/16-18h.	3	7,94 6,60 56x22x 4,9	39,62*	25x 9	30,65*	
UNC 3/8-16h.	3	9,52 8,00 70x24x 5,5	45,08*	30x11	42,60*	
UNC7/16-14h.	3	11,11 9,40 70x24x 6,2	58,70	38x14	42,60	
UNC 1/2-13h.	3	12,70 10,75 75x29x 7,0	67,54*	38x14	43,80*	
UNC9/16-12h.	3	14,28 12,20 80x30x 9,0	79,73	38x14	45,84	
UNC 5/8-11h.	3	15,87 13,50 80x32x 9,0	109,95*	45x18	62,14*	
UNC 3/4-10h.	3	19,05 16,50 95x40x11,0	149,82*	45x18	62,14*	
UNC 7/8-9h.	3	22,22 19,50 100x40x14,5	184,43	55x22	86,75	
UNC 1"-8h.	3	25,40 22,25 110x50x14,5	249,05*	55x22	83,41*	
UNC 1.1/8-7h.	3	28,57 25,00 125x56x18,0	375,51	65x25	123,90	
UNC 1.1/4-7h.	3	31,75 28,00 125x56x18,0	472,65	65x25	123,90	
UNC 1.3/8-6h.	3	34,92 30,75 150x63x22,0	599,61	65x25	123,90	
UNC 1.1/2-6h.	3	38,10 34,00 150x63x24,0	736,21	75x30	193,18	
UNC 2"-4,5h.	3	50,80 45,00 180x75x32,0	1.585,74	90x36		

Ud	D1 mm	L1 x L2 x L3 mm	M0		C5	
			€	Ø x L3 mm	€	
UNF n° 2-64h.	2	2,18 1,85 36x 8x 2,1	50,97			
UNF n° 3-56h.	2	2,51 2,15 40x 9x 2,1	50,97			
UNF n° 4-48h.	2	2,84 2,35 40x 9x 2,7	31,76	20x 5	32,85	
UNF n° 5-44h.	2	3,17 2,70 45x10x 2,7	31,76	20x 5	31,69	
UNF n° 6-40h.	2	3,50 2,95 45x16x 3,0	30,35	20x 5	31,69	
UNF n° 8-36h.	2	4,17 3,50 50x12x 3,4	30,35	20x 7	31,69	
UNF n°10-32h.	2	4,83 4,10 50x12x 4,9	30,35	20x 7	31,69	
UNF n°12-28h.	2	5,49 4,60 50x12x 4,9	31,76	20x 7	31,69	
UNF 1/4-28h.	2	6,35 5,50 50x14x 4,9	23,16*	25x 9	27,98*	
UNF 5/16-24h.	2	7,94 6,90 56x22x 4,9	24,80*	25x 9	31,23*	
UNF 3/8-24h.	2	9,52 8,50 63x20x 5,5	28,63*	38x10	42,60*	
UNF 7/16-20h.	2	11,11 9,90 63x20x 6,2	38,01	38x10	41,80	
UNF 1/2-20h.	2	12,70 11,50 70x22x 7,0	38,88*	38x10	45,55*	
UNF 9/16-18h.	2	14,29 12,90 70x22x 9,0	50,66	38x10	47,68	
UNF 5/8-18h.	2	15,87 14,50 70x22x 9,0	65,44*	45x14	62,14*	
UNF 3/4-16h.	2	19,05 17,50 80x22x11,0	87,91*	45x14	62,14*	
UNF 7/8-14h.	2	22,22 20,40 80x22x14,5	112,97*	55x16	83,41*	
UNF 1"-12h.	2	25,40 23,25 90x22x16,0	149,80	55x16	83,41	
UNS 1"-14h.	2	25,40 23,60 90x22x14,5	159,79*	55x16	90,63*	
UNF 1.1/8-12h.	2	28,57 26,50 90x22x18,0	205,17	65x18	94,25	
UNF 1.1/4-12h.	2	31,75 29,50 90x22x20,0	250,57	65x18	128,86	
UNF 1.3/8-12h.	2	34,92 32,80 125x35x22	364,28	65x18	134,90	
UNF 1.1/2-12h.	2	38,10 36,00 125x40x22	460,22	75x20	193,18	
UNF 2"-12h.	2	50,80 48,38 140x40x29	1.138,76	90x22		

* Disponibles también con rosca izquierda con 100% de recargo sobre los precios tarifados en rosca derecha

MACHOS Y TERRAJAS PARA ROSCAR A MANO HSS

NPTF

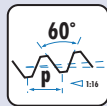

Rosca AMERICANA
Rosca Cónica
estanca

Ref. **M0**

HSS

Ref. **C5**

HSS

DIN
223

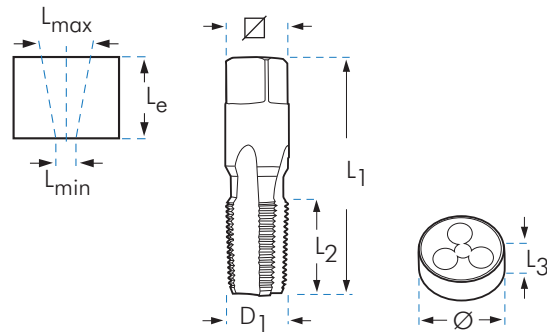

Ud s	D ₁ mm	Ø	L _{min} x L _{max} mm	L _e mm	L ₁ x L ₂ x ∅ mm	M0		C5	
						€	Ø x L ₃ mm	€	
1/16-27 h.	1	7,87	6,2	6,00 x 6,41	12,0	56 x 14 x 4,9		25 x 11	
1/8-27 h.	1	10,22	8,5	8,30 x 8,76	12,0	63 x 15 x 5,5	72,55	38 x 10	158,45
1/4-18 h.	1	13,58	11,0	10,70 x 11,40	17,5	70 x 21 x 9,0	101,69	38 x 15	158,45
3/8-18 h.	1	17,02	14,5	14,20 x 14,84	17,6	70 x 21 x 9,0	140,38	45 x 15	206,88
1/2-14 h.	1	21,21	17,8	17,40 x 18,33	22,8	80 x 27 x 12,0	196,30	45 x 20	206,88
3/4-14 h.	1	26,56	23,0	22,80 x 23,68	23,0	100 x 27 x 16,0	300,06	55 x 22	394,30
1"-11,5 h.	1	33,19	29,0	28,60 x 29,72	27,4	110 x 32 x 20,0	399,68	65 x 25	

NPT

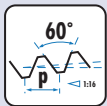

Rosca AMERICANA
Rosca Cónica
no estanca (Briggs)

Ref. **M0**

HSS

Ref. **C5**

HSS

DIN
223

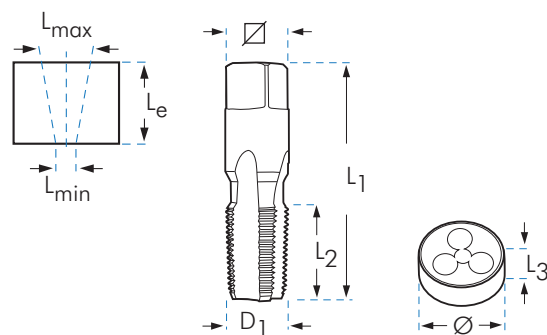

Ud s	D ₁ mm	Ø	L _{min} x L _{max} mm	L _e mm	L ₁ x L ₂ x ∅ mm	M0		C5	
						€	Ø x L ₃ mm	€	
1/16-27 h.	1	7,89	6,20	6,00 x 6,38	12,0	56 x 14 x 4,9	26,77	25 x 11	86,87
1/8-27 h.	1	10,24	8,50	8,30 x 8,73	12,0	63 x 15 x 5,5	26,77	38 x 10	66,69
1/4-18 h.	1	13,62	11,00	10,70 x 11,35	17,5	70 x 21 x 9,0	37,56	38 x 15	66,69
3/8-18 h.	1	17,05	14,50	14,20 x 14,80	17,6	70 x 21 x 9,0	51,83	45 x 15	87,07
1/2-14 h.	1	21,23	17,80	17,40 x 18,32	22,8	80 x 27 x 12,0	72,47	45 x 20	87,07
3/4-14 h.	1	26,57	23,00	22,80 x 23,66	23,0	100 x 27 x 16,0	110,80	55 x 22	159,29
1"-11,5 h.	1	33,23	29,00	28,60 x 29,69	27,4	110 x 32 x 20,0	123,40	65 x 25	191,48
1 1/4-11,5 h.	1	41,98	37,50	37,40 x 38,45	28,1	125 x 33 x 24,0	202,32	75 x 25	237,95
1 1/2-11,5 h.	1	48,05	44,00	43,40 x 44,52	28,4	140 x 33 x 29,0	307,43	90 x 26	331,98
2"-11,5 h.	1	60,09	56,00	55,50 x 56,56	28,4	160 x 33 x 35,0	479,95	105 x 26	462,20

MACHOS Y TERRAJAS PARA ROSCAR A MANO HSS

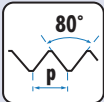

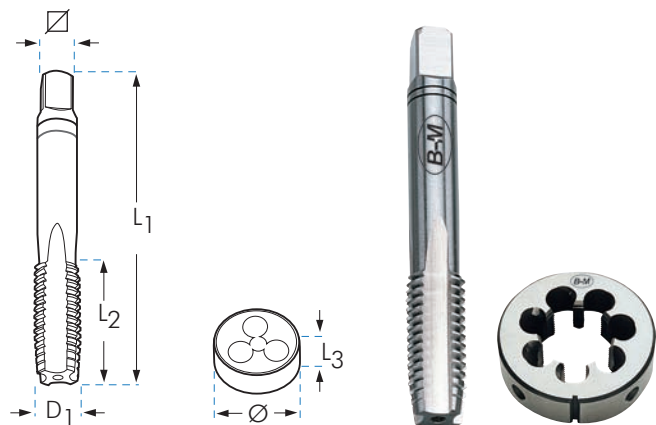
PG  Ref. **MO** **HSS** **DIN 40430** Ref. **C5** **HSS** **DIN 223**

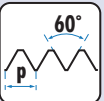

					MO		C5	
		Ud s	D ₁ mm		L ₁ x L ₂ x 	€	Ø x L ₃ mm	€
Pg 7	20h	1	12,5	11,50	70x20x 7,0	31,57	38x10	61,69
Pg 9	18h	1	15,2	14,00	70x20x 9,0	40,14	38x10	61,69
Pg 11	18h	1	18,6	17,25	80x22x11,0	55,73	45x14	77,24
Pg 13,5	18h	1	20,4	19,00	80x22x12,0	61,12	45x14	77,24
Pg 16	18h	1	22,5	21,25	80x22x14,5	73,40	55x16	99,65
Pg 21	16h	1	28,3	27,00	90x22x18,0	107,94	65x18	141,64
Pg 29	16h	1	37,0	35,50	100x25x22,0	214,33	65x18	141,64
Pg 36	16h	1	47,0	45,50	140x32x29,0	324,15	90x22	363,05
Pg 42	16h	1	54,0	52,50	140x36x32,0	384,94	105x22	363,05
Pg 48	16h	1	59,3	58,00	160x36x35,0	485,48	105x22	481,44

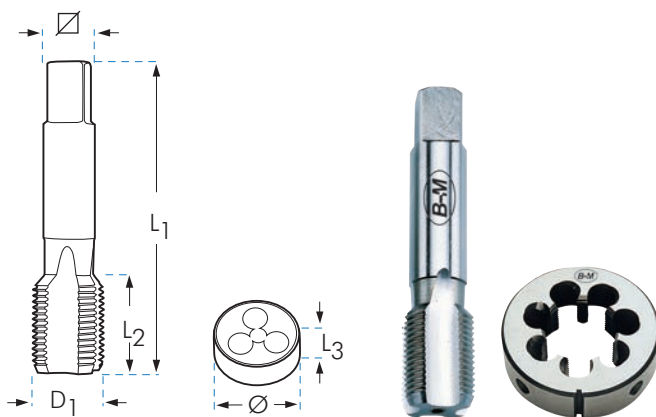



NPSF  Rosca AMERICANA
Rosca Cilíndrica
estanca Ref. **MO** **HSS** Ref. **C5** **HSS** **DIN 223**

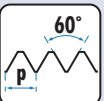

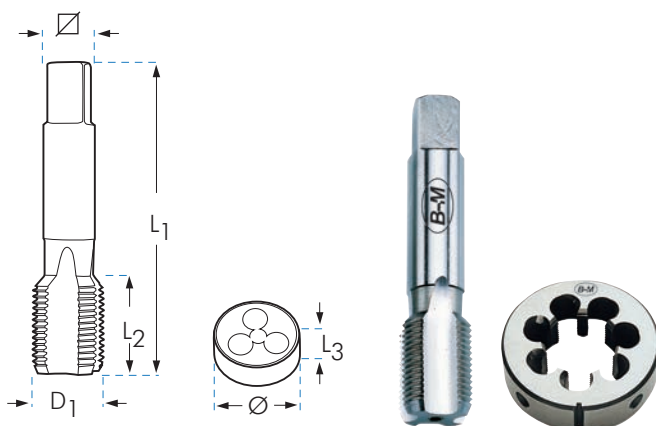
					MO		C5	
		Ud s	D ₁ mm		L ₁ x L ₂ x 	€	Ø x L ₃ mm	€
1/8 - 27 h.	1	10,05	8,75	63x18x 5,5	109,25	38x10	190,34	
1/4 - 18 h.	1	13,35	11,30	70x20x 9,0	157,88	38x10	190,34	
3/8 - 18 h.	1	16,78	14,70	70x20x 9,0	218,38	45x14	242,13	
1/2 - 14 h.	1	20,87	18,20	80x22x12,0	285,49	45x14	242,13	
3/4 - 14 h.	1	26,23	23,50	90x22x16,0	434,38	55x16	523,38	
1" - 11,5 h.	1	32,81	29,50	100x25x20,0				

NPS (M)  Rosca AMERICANA
Rosca Cilíndrica
no estanca Ref. **MO** **HSS** Ref. **C5** **HSS** **DIN 223**



					MO		C5	
		Ud s	D ₁ mm		L ₁ x L ₂ x 	€	Ø x L ₃ mm	€
1/8 - 27 h.	1	10,08	9,1	63x18x 5,5	90,53	38x10	158,57	
1/4 - 18 h.	1	13,36	12,0	70x20x 9,0	72,05	38x10	158,57	
3/8 - 18 h.	1	16,81	15,5	70x20x 9,0	99,65	45x14	201,77	
1/2 - 14 h.	1	20,90	19,0	80x22x12,0	130,24	45x14	201,77	
3/4 - 14 h.	1	26,26	24,5	90x22x16,0	189,15	55x16	399,70	
1" - 11,5 h.	1	32,84	30,5	100x25x20,0	264,47	65x18	392,30	

JUEGOS DE MACHOS Y TERRAJAS PARA ROSCAR A MANO HSS

BSPT

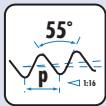

HSS

DIN 5157

HSS

DIN 223

Ref. **M0**

Ref. **C5**

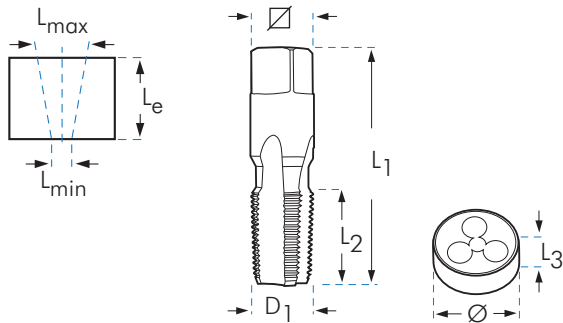

Ud	s	D ₁ mm	Ø	L _{min} x L _{max} mm	L _e mm	L ₁ x L ₂ x √ mm	M0		C5	
							€	Ø x L ₃ mm	€	
1	1	9,73	8,30	8,00 x 8,50	10,1	63 x 15 x 5,5	30,07	30 x 11	94,74	
1	1	13,16	11,00	10,70 x 11,35	15,0	79 x 19 x 9,0	42,36	38 x 14	94,74	
1	1	16,66	14,50	14,15 x 14,25	15,4	70 x 21 x 9,0	58,84	45 x 16	123,39	
1	1	20,95	18,10	17,60 x 18,50	20,5	80 x 26 x 12,0	82,37	55 x 22	123,39	
1	1	22,91	20,00	19,50 x 20,40	22,4	90 x 36 x 14,4	132,91	55 x 19	257,47	
1	1	26,44	23,50	23,00 x 24,00	21,8	90 x 28 x 16,0	123,67	55 x 22	233,01	
1	1	30,20	27,25	26,65 x 28,75	24,0	100 x 36 x 18,0	262,15	65 x 22	336,37	
1	1	33,25	29,60	29,00 x 30,20	26,0	100 x 33 x 20,0	212,88	65 x 25	269,08	

BA

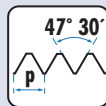

HSS

DIN 352

HSS

DIN 223

Ref. **M0**

Ref. **C5**

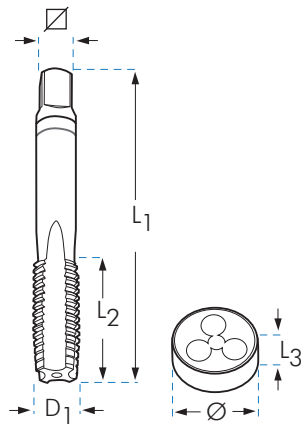

Ud	s	D ₁ mm	Ø	L ₁ x L ₂ x √ mm	M0		C5	
					€	Ø x L ₃ mm	€	
1,00	3	6,0	5,1	50 x 18 x 4,9	164,14	20 x 5	130,75	
0,90	3	5,3	4,5	50 x 18 x 4,9	164,14	20 x 5	130,75	
0,81	3	4,7	4,0	50 x 17 x 4,9	164,14	20 x 5	130,75	
0,73	3	4,1	3,4	45 x 14 x 3,4	176,39	20 x 5	130,75	
0,66	3	3,6	3,0	45 x 14 x 3,0	176,39	20 x 5	130,75	
0,59	3	3,2	2,6	45 x 14 x 3,0	210,76	20 x 5	130,75	
0,53	3	2,8	2,3	40 x 12 x 2,7	210,76	20 x 5	130,75	
0,48	3	2,5	2,0	40 x 10 x 2,1	231,72	20 x 5	130,75	
0,43	3	2,2	1,8	36 x 10 x 2,1	231,72	20 x 5	130,75	

MACHOS Y TERRAJAS PARA ROSCAR A MANO HSS

UNx8

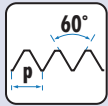

Rosca AMERICANA

Ref. **MO**

HSS

DIN 2181

TOL 2B

Ref. **C5**

HSS

DIN 223

TOL 2a

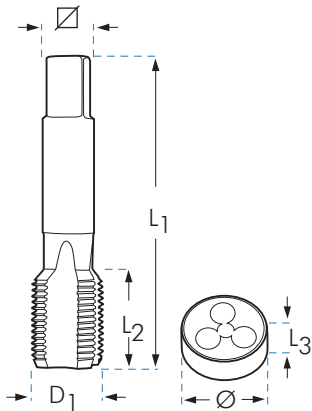

Ud s	D1 mm	L1 x L2 x Ø mm	MO		C5	
			€	Ø x L3 mm	€	
1" 1/8-8h.	2 28,57	25,40	138x65x17,0	309,53	65x25	332,74
1" 1/4-8h.	2 31,75	28,50	146x65x19,5	401,40	65x25	332,74
1" 3/8-8h.	2 34,92	31,75	154x76x21,0	499,24	65x25	331,28
1" 1/2-8h.	2 38,10	35,00	162x76x23,5	571,33	75x30	375,04
1" 5/8-8h.	2 41,27	38,10	170x80x25,0	710,32	75x30	392,56
1" 3/4-8h.	2 44,45	41,25	178x81x27,0	885,26	90x36	457,99
1" 7/8-8h.	2 47,62	44,45	186x90x29,0	1.104,41	90x36	490,04
2"-8h.	2 50,80	47,63	194x90x31,5	1.049,97	90x36	457,99
2" 1/4-8h.	2 57,15	54,00	208x90x36,0		120x36	
2" 1/2-8h.	2 63,50	60,35	220x100x40		120x36	
2" 3/4-8h.	2 69,85	66,70	198x48x39,0		120x36	
3"-8h.	2 76,20	73,05	248x115x49		120x36	

UNEF

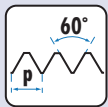

Rosca AMERICANA

Ref. **MO**

HSS

DIN 2181

TOL 2B

Ref. **C5**

HSS

DIN 223

TOL 2a

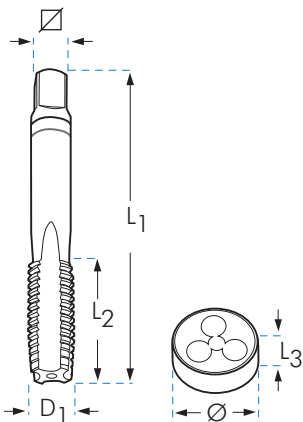

Ud s	D1 mm	L1 x L2 x Ø mm	MO		C5	
			€	Ø x L3 mm	€	
1/4-32h.	2 6,35	5,55	65x28x 4,9	103,06	20x 7	102,03
5/16-32h.	2 7,94	7,15	70x30x 6,0	115,14	25x 9	102,03
3/8-32h.	2 9,52	8,70	75x33x 7,0	131,76	30x11	158,42
7/16-28h.	2 11,11	10,20	81x38x 6,0	167,73	30x11	158,42
1/2-28h.	2 12,70	11,80	86x44x 7,0	189,52	38x10	158,42
9/16-24h.	2 14,29	13,20	92x44x 8,0	221,70	38x10	158,42
5/8-24h.	2 15,87	14,80	93x47x 9,0	308,59	45x14	253,93
3/4-20h.	2 19,05	17,80	108x52x11,0	456,96	45x14	253,93
7/8-20h.	2 22,22	20,95	120x58x13,0	678,89	55x16	313,43
1"-20h.	2 25,40	24,20	130x65x15,0	653,84	55x16	310,33

JUEGOS DE MACHOS PARA ROSCAR A MANO APLICACIONES ESPECIALES

1100
N/mm²

Ref. **MOMD**

HSS-Co
5%

OX



ESPECIAL MATERIALES DUROS (< 1100 N/mm²)

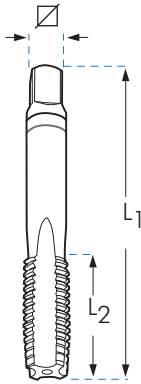

		Uds	Ø	L ₁ x L ₂ x	MOMD
				mm	€
M 3 x 0,50	3	2,50	40 x 11 x 2,7	28,24	
M 4 x 0,70	3	3,30	45 x 13 x 3,4	28,24	
M 5 x 0,80	3	4,20	50 x 17 x 4,9	29,09	
M 6 x 1,00	3	5,00	50 x 19 x 4,9	29,09	
M 8 x 1,25	3	6,80	56 x 20 x 4,9	34,38	
M 10 x 1,50	3	8,50	70 x 22 x 5,5	44,13	
M 12 x 1,75	3	10,20	75 x 24 x 7,0	63,19	
M 14 x 2,00	3	12,00	80 x 26 x 9,0	71,94	
M 16 x 2,00	3	14,00	80 x 27 x 9,0	95,59	
M 18 x 2,50	3	15,50	95 x 30 x 11,0	154,36	
M 20 x 2,50	3	17,50	95 x 32 x 12,0	171,38	

1400
N/mm²

Ref. **MOC**

HSS-Co
5%

TiCN



ESPECIAL MATERIALES MUY DUROS (≤ 1400 N/mm²)

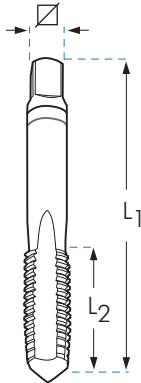

		Uds	Ø	L ₁ x L ₂ x	MOC
				mm	€
M 3 x 0,50	3	2,50	40 x 11 x 2,7	72,70	
M 4 x 0,70	3	3,30	45 x 13 x 3,4	78,44	
M 5 x 0,80	3	4,20	50 x 17 x 4,9	79,42	
M 6 x 1,00	3	5,00	50 x 19 x 4,9	79,42	
M 8 x 1,25	3	6,80	56 x 20 x 4,9	89,52	
M 10 x 1,50	3	8,50	70 x 22 x 5,5	110,66	
M 12 x 1,75	3	10,20	75 x 24 x 7,0	134,52	
M 14 x 2,00	3	12,00	80 x 26 x 9,0	165,07	
M 16 x 2,00	3	14,00	80 x 27 x 9,0	197,78	
M 18 x 2,50	3	15,50	95 x 30 x 11,0	274,20	
M 20 x 2,50	3	17,50	95 x 32 x 12,0	301,79	

Al

Ref. **MOAL**

HSS

BRILLANTE



ESPECIAL ALUMINIO

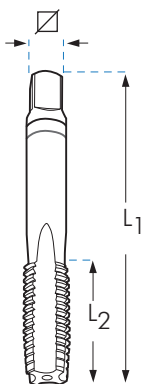

		Uds	Ø	L ₁ x L ₂ x	MOAL
				mm	€
M 3 x 0,50	3	2,50	40 x 11 x 2,7	22,73	
M 4 x 0,70	3	3,30	45 x 13 x 3,4	22,07	
M 5 x 0,80	3	4,20	50 x 17 x 4,9	23,38	
M 6 x 1,00	3	5,00	50 x 19 x 4,9	23,38	
M 8 x 1,25	3	6,80	56 x 20 x 4,9	28,71	
M 10 x 1,50	3	8,50	70 x 22 x 5,5	35,06	
M 12 x 1,75	3	10,20	75 x 24 x 7,0	49,35	
M 14 x 2,00	3	12,00	80 x 26 x 9,0	56,71	
M 16 x 2,00	3	14,00	80 x 27 x 9,0	80,49	
M 18 x 2,50	3	15,50	95 x 30 x 11,0	106,68	
M 20 x 2,50	3	17,50	95 x 32 x 12,0	120,27	

MACHOS Y TERRAJAS PARA ROSCAR A MANO INOXIDABLE

INOX

Ref. **MOT**
Ref. **MOX**

DIN 352

TOL 6H

TiN

Ref. **C5T**
Ref. **C5X**

DIN 223

TOL 6g

OX

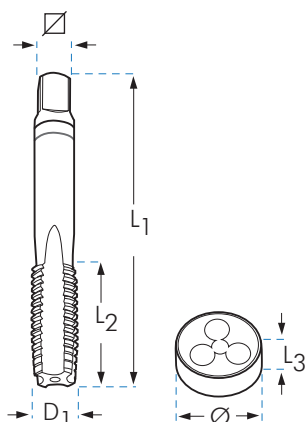

			MOT		C5T	MOX		C5X	
			HSS	TiN	HSS	HSS-Co	OX	HSS-Co	OX
	Ud s	L ₁ x L ₂ x ∅ mm	€	€	€	€	€	∅ x L ₃ mm	
M 2 x 0,40	3	36 x 9 x 2,10							
M 3 x 0,50	3	40 x 11 x 2,70	31,34		46,95	26,89	37,01	20 x 5	
M 4 x 0,70	3	45 x 13 x 3,40	34,53		46,95	26,89	37,01	20 x 5	
M 5 x 0,80	3	50 x 16 x 4,90	36,63		46,95	27,99	41,56	20 x 7	
M 6 x 1,00	3	50 x 19 x 4,90	36,63		46,95	27,91	42,16	20 x 7	
M 8 x 1,00	2	50 x 19 x 4,90	30,71						
M 8 x 1,25	3	56 x 22 x 4,90	42,25		48,13	32,49	45,72	25 x 9	
M 10 x 1,00	2	63 x 18 x 5,50	35,43						
M 10 x 1,50	3	70 x 24 x 5,50	54,68		63,19	41,80	58,01	30 x 11	
M 12 x 1,50	2	70 x 20 x 7,00	45,11						
M 12 x 1,75	3	75 x 29 x 7,00	62,26		70,07	59,84	61,28	38 x 14	
M 14 x 1,50	2	70 x 20 x 9,00	54,18					45 x 18	
M 14 x 2,00	3	80 x 30 x 9,00	75,29		70,07	66,27	61,28		
M 16 x 2,00	3	80 x 32 x 9,00	94,55		86,34	90,83	82,28		
M 18 x 2,50	3	95 x 40 x 11,00	119,44			124,05			
M 20 x 2,50	3	95 x 40 x 12,00	130,06			137,68			
M 22 x 2,50	3	100 x 40 x 14,50	156,68						
M 24 x 3,00	3	110 x 50 x 14,50	188,79						

M

BSP (GAS)

BSP 1/8-28 h.	2	63 x 20 x 5,50	57,90	74,35	66,52	76,56
BSP 1/4-19 h.	2	70 x 22 x 9,00	105,35	76,94	119,55	76,77
BSP 3/8-19 h.	2	70 x 22 x 9,00	128,52	86,56	148,51	82,19
BSP 1/2-14 h.	2	80 x 22 x 12,00	181,15	97,98	200,38	103,94
BSP 3/4-14 h.	2	90 x 22 x 16,00	237,65	159,63	287,63	170,00
BSP 1" -11 h.	2	100 x 25 x 20,00	414,20	213,22	473,08	247,10

BSW

BSW 3/16-24 h.	3	50 x 19 x 4,90	43,87	43,86		
BSW 1/4-20 h.	3	50 x 20 x 4,90	49,11	44,65		
BSW 5/16-18 h.	3	56 x 20 x 4,90	53,81	46,42		
BSW 3/8-16 h.	3	63 x 22 x 5,50	63,33	54,88		
BSW 1/2-12 h.	3	75 x 25 x 7,00	89,37	73,73		

CONJUNTOS DE MACHOS Y COJINETES EN CAJA METÁLICA HSS

**M3
M12**

HSS



Ref. **D624**

CONTENIDO						P.V.P. €	
						1ª	2ª
						Calidad	Calidad
D624	M3 - M4 - M5 - M6 - M8 - M10 - M12	Nº 1.1/2	25 x 9	-		243,37	211,26

CONJUNTOS DE COJINETES EN CAJA METÁLICA HSS

**M3
M12**

HSS



Ref. **D671**

CONTENIDO					P.V.P. €	
					1ª	2ª
					Calidad	Calidad
D671	M3 - M4 - M5 - M6 - M8 - M10 - M12	20 x 5 30 x 11	20 x 7 38 x 14	25 x 9	198,80	168,38
D6711 (lza)	M3 - M4 - M5 - M6 - M8 - M10 - M12	20 x 5 30 x 11	20 x 7 38 x 14	25 x 9	397,59	336,75

CONJUNTOS DE MACHOS Y COJINETES EN CAJA METÁLICA HSS y HSS-Co

**M3
M12**



HSS



Ref. **D621**



Ref. **D655**

CONTENIDO

P.V.P. €

								1ª Calidad	2ª Calidad
D621	M3 - M4 - M5 - M6 M8 - M10 - M12		2.5 / 3.3 / 4.2 / 5.0 6.8 / 8.5 / 10.2 mm	Nº 1 Nº 2	20 x 5 30 x 11	20 x 7 38 x 14	25 x 9	TC1	422,30 293,94
D652	M3 - M4 - M5 - M6 M8 - M10 - M12		2.5 / 3.3 / 4.2 / 5.0 6.8 / 8.5 / 10.2 mm	Nº 1 Nº 2	20 x 5 30 x 11	20 x 7 38 x 14	25 x 9	-	391,18 309,53
D662	M3 - M4 - M5 - M6 M7 - M8 - M9 - M10 M11 - M12		-	Nº 1 Nº 2	20 x 5 30 x 11	20 x 7 38 x 14	25 x 9	TC1	782,61 688,37
D651	M3 - M4 - M5 - M6 M8 - M10 - M12		-	Nº 1 Nº 2	20 x 5 30 x 11	20 x 7 38 x 14	25 x 9	-	322,64 284,04
D655* (HSS-Co)	M3 - M4 - M5 - M6 M8 - M10 - M12		2.5 / 3.3 / 4.2 / 5.0 6.8 / 8.5 / 10.2 mm	Nº 1 Nº 2	20 x 5 30 x 11	20 x 7 38 x 14	25 x 9	TC1	644,67* 567,06*
D6211 (Izq)	M3 - M4 - M5 - M6 M8 - M10 - M12		2.5 / 3.3 / 4.2 / 5.0 6.8 / 8.5 / 10.2 mm	Nº 1 Nº 2	20 x 5 30 x 11	20 x 7 38 x 14	25 x 9	TC1	631,14 550,41

*

CONJUNTOS DE MACHOS Y COJINETES EN CAJA METÁLICA HSS y HSS-Co CON GUÍAS PARA COJINETES



M3
M12



HSS



	CONTENIDO							P.V.P. €	
							1ª Calidad	2ª Calidad	
D656	M3 - M4 - M5 - M6 M8 - M10 - M12		2.5 / 3.3 / 4.2 / 5.0 6.8 / 8.5 / 10.2 mm	Nº 1 Nº 2	20 x 5 20 x 7 30 x 11 38 x 14	25 x 9	TC1	451,59	399,76
D657* (HSS-Co)	M3 - M4 - M5 - M6 M8 - M10 - M12		2.5 / 3.3 / 4.2 / 5.0 6.8 / 8.5 / 10.2 mm	Nº 1 Nº 2	20 x 5 20 x 7 30 x 11 38 x 14	25 x 9	TC1	672,27*	593,36*

*   

CONJUNTOS DE MACHOS Y COJINETES EN CAJA METÁLICA HSS y HSS-Co

M3
M20

M5
M20

HSS



Ref. **D622**



Ref. **D623**

CONTENIDO

P.V.P. €

							1ª Calidad	2ª Calidad
D622 (Automoción)	M3 - M4 - M5 - M6 - M8 - M10 - M12 M14 - M16 - M18 - M20	Nº 1 Nº 3	20 x 5 30 x 11	20 x 7 38 x 14	25 x 9 45 x 18	TC1 TC2	756,66	608,44
D658	M3 - M4 - M5 - M6 - M8 - M10 - M12 M14 - M16 - M18 - M20	Nº 1 Nº 3	20 x 5 30 x 11	20 x 7 38 x 14	25 x 9 45 x 18	-	728,43	601,13
D6221 (Izq)	M3 - M4 - M5 - M6 - M8 - M10 - M12 M14 - M16 - M18 - M20	Nº 1 Nº 3	20 x 5 30 x 11	20 x 7 38 x 14	25 x 9 45 x 18	TC1 TC2	1.190,27	1.128,51
D659* (HSS-Co)	M3 - M4 - M5 - M6 - M8 - M10 - M12 M14 - M16 - M18 - M20	Nº 1 Nº 3	20 x 5 30 x 11	20 x 7 38 x 14	25 x 9 45 x 18	-	1.435,73*	1.262,86*
D623	M5 - M6 - M8 - M10 - M12 M14 - M16 - M18 - M20	Nº 1 Nº 3	20 x 7 30 x 11	25 x 9 38 x 14	45 x 18	TC1 TC2	724,66	592,87
D663	M5 - M6 - M7 - M8 - M9 - M10 - M12 M14 - M16 - M18 - M20	Nº 1 Nº 3	20 x 7 38 x 14	25 x 9 45 x 18	30 x 11	-	966,13	869,01



CONJUNTOS DE MACHOS Y COJINETES EN CAJA METÁLICA HSS

M1 M10
M5 M12
M3 M24
M5 M30
HSS



Ref. **D628**



Ref. **D626**

	CONTENIDO	P.V.P. €			
		1ª Calidad	2ª Calidad		
D626	 M1 - M1.2 - M1.4 - M1.7 - M2.0 - M2.3 M2.6 - M3 - M3.5 - M4 - M5 - M6 - M8 - M10 N° 0 N° 1	16 x 5 25 x 9	20 x 5 30 x 11	20 x 7 TC1	903,99
D627	M5 - M6 - M7 - M8 - M9 - M10 - M11 - M12 N°1 N°2	20 x 7 38 x 14	25 x 9 30 x 11	30 x 11 TC1	675,32
D625	M3 - M4 - M5 - M6 - M8 - M10 - M12 - M14 M16 - M18 - M20 - M22 - M24 N°1 N°4	20 x 5 30 x 11 55 x 22	20 x 7 38 x 14 45 x 18	25 x 9 45 x 18 -	1.595,04 1.176,88
D628	M5 - M6 - M8 - M10 - M12 - M14 - M16 M18 - M20 - M22 - M24 - M27 - M30 N°1 N°3 N°5	20 x 7 38 x 14 65 x 25	25 x 9 45 x 18 55 x 22	30 x 11 55 x 22 -	2.251,08

CONJUNTOS DE MACHOS Y COJINETES EN CAJA METÁLICA HSS

MF

HSS



Ref. **D634**



Ref. **D636**

CONTENIDO

P.V.P. €



1ª
Calidad

2ª
Calidad

D634	MF 3 x 0.35 - 4 x 0.5 - 5 x 0.5 MF 6 x 0.75 - 8 x 0.75 - 8 x 1.0 MF 10 x 1.0 - 12 x 1.5	Nº 1 Nº 2	20 x 5 25 x 9 30 x 11 38 x 10		TC1			647,47
D635	MF 6 x 0.75 - 8 x 0.75 - 8 x 1.0 - 10 x 1.0 MF 12 x 1.0 - 12 x 1.5 - 14 x 1.25 - 14 x 1.5 MF 16 x 1.5 - 18 x 1.5 - 20 x 1.5	Nº 1 Nº 3	20 x 7 25 x 9 30 x 11 38 x 10 45 x 14		-		1.010,67	961,08
D636	MF 6 x 0.75 - 8 x 0.75 - 8 x 1.0 - 10 x 1.0 MF 12 x 1.0 - 12 x 1.5 - 14 x 1.25 - 14 x 1.5 MF 16 x 1.5 - 18 x 1.5 - 20 x 1.5 - 22 x 1.5 MF 24 x 1.5	Nº 1 Nº 4	20 x 7 25 x 9 30 x 11 38 x 10 45 x 14 55 x 16		-		1.386,46	1.281,88

CONJUNTOS DE MACHOS Y COJINETES EN CAJA METÁLICA HSS

**BSP
(GAS)**

HSS



Ref. **D638**

CONTENIDO

P.V.P. €

							1ª Calidad	2ª Calidad
D637	G 1/8 - 1/4 - 3/8 - 1/2 - 3/4 - 1"	Nº1 Nº3 Nº5	30 x 11 55 x 16	38 x 10 65 x 18	45 x 14	-	1.122,16	947,26
D638	G 1/8 - 1/4 - 3/8 - 1/2 - 5/8 - 3/4 - 7/8 - 1"	Nº1 Nº3 Nº5	30 x 11 55 x 16	38 x 10 65 x 18	45 x 14	-	1.522,89	1.329,37
D639	G 1/4 - 3/8 - 1/2 - 3/4 - 1" - 1".1/4 - 1".1/2	Nº2 Nº4 Nº7	38 x 10 65 x 18	45 x 14 75 x 20	55 x 16 90 x 22	-	2.809,47	2.476,55

BSW

HSS



Ref. **D640**

CONTENIDO

P.V.P. €

							1ª Calidad	2ª Calidad
D640	BSW 1/8-3/16-1/4-5/16-3/8-7/16-1/2	Nº1 Nº2	20 x 5 30 x 11	20 x 7 38 x 14	25 x 9	TC1	626,01	559,22
D641	BSW 1/4-5/16-3/8-7/16-1/2	Nº1 Nº2	20 x 7 38 x 14	25 x 9	30 x 11	TC1	516,07	454,23
D642	BSW 1/4-5/16-3/8-7/16-1/2-5/8-3/4	Nº1 Nº3	20 x 7 38 x 14	25 x 9 45 x 18	30 x 11	-	923,57	842,72
D643	BSW 1/4-5/16-3/8-7/16-1/2-5/8 3/4-7/8-1"	Nº1 Nº4	20 x 7 38 x 14	25 x 9 45 x 18	30 x 11 55 x 22	-	1.306,13	1.198,34
D646	BSW 1/4-5/16-3/8-7/16-1/2-5/8-3/4 7/8-1"-1".1/8-1".1/4-1".3/8-1".1/2	Nº1 Nº3 Nº5	20 x 7 38 x 14 65 x 25	25 x 9 45 x 18	30 x 11 55 x 22	-		3.484,67

CONJUNTOS DE MACHOS Y COJINETES EN CAJA METÁLICA HSS

BSF

HSS



Ref. **D648**

CONTENIDO

P.V.P. €

						1ª Calidad	2ª Calidad
D664	BSF 1/4 - 5/16 - 3/8 - 7/16 - 1/2		Nº1 Nº2	20 x 7 38 x 10	25 x 9 30 x 11	TC1	577,11 507,62
D648	BSF 1/4-5/16 -3/8 -7/16 -1/2 -5/8 -3/4		Nº1 Nº3	20 x 7 38 x 10	25 x 9 45 x 14	-	895,90 842,72
D665	BSF 1/4-5/16 -3/8 -7/16 -1/2 -5/8 3/4 - 7/8 - 1"		Nº1 Nº4	20 x 7 38 x 10	25 x 9 45 x 14 30 x 11 55 x 16	-	1.520,19 1.337,15

**BSW
BSF**





HSS

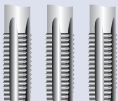

Ref. **D666**

CONTENIDO

P.V.P. €

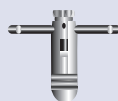
						1ª Calidad	2ª Calidad
D666	BSW 1/4 - 5/16 - 3/8 - 7/16 - 1/2 - 5/8 - 3/4 BSF 1/4 - 5/16 - 3/8 - 7/16 - 1/2 - 5/8 - 3/4		Nº1 Nº3	20 x 7 38 x 14	25 x 9 45 x 18	-	1.717,25 1.510,48

CONJUNTOS DE MACHOS Y COJINETES EN CAJA METÁLICA HSS

NPT

HSS



Ref. **D660**

CONTENIDO

P.V.P. €

	Machos	Cojinetes	Machos	Cojinetes	Machos	Cojinetes	P.V.P. €	
							1ª Calidad	2ª Calidad
D660	NPT 1/8 - 1/4 - 3/8 - 1/2 - 3/4 - 1"	Nº1 Nº3 Nº5	30 x 11 55 x 22	38 x 14 65 x 25	45 x 18	-	1.623,25	1.539,73
D661	NPT 1/8 - 1/4 - 3/8 - 1/2 - 5/8 - 3/4 1" - 1 1/4 - 1 1/2 - 2"	Nº2 Nº4 Nº7	30 x 11 55 x 22 90 x 36	38 x 14 65 x 25 105 X 36	45 x 18 75 x 30	-	4.859,19	4.565,19

UNC

HSS



Ref. **D650**

CONTENIDO

P.V.P. €

	Machos	Cojinetes	Machos	Cojinetes	Machos	Cojinetes	P.V.P. €	
							1ª Calidad	2ª Calidad
D650	UNC 1/4 - 5/16 - 3/8 - 7/16 - 1/2	Nº1 Nº2	20 x 7 38 x 14	25 x 9 45 x 18	30 x 11	TC1	629,02	564,57
D667	UNC 1/4 - 5/16 - 3/8 - 7/16 - 1/2 - 5/8 - 3/4	Nº1 Nº2	20 x 7 38 x 14	25 x 9 45 x 18	30 x 11	-	1.013,46	891,43
D654	UNC 1/4 - 5/16 - 3/8 - 7/16 - 1/2 - 5/8 3/4 - 7/8 - 1"	Nº1 Nº4	20 x 7 38 x 14	25 x 9 45 x 18	30 x 11 55 x 22	-	1.635,31	1.530,45
D668	UNC 1/4 - 5/16 - 3/8 - 7/16 - 1/2 - 5/8 - 3/4 7/8 - 1" - 1 1/8 - 1 1/4 - 1 3/8 - 1 1/2"	Nº1 Nº3 Nº6	20 x 7 38 x 14 65 x 25	25 x 9 45 x 18	30 x 11 55 x 22	-	3.828,62	3.367,63

CONJUNTOS DE MACHOS Y COJINETES EN CAJA METÁLICA HSS

UNF

HSS



Ref. **D644**

CONTENIDO

P.V.P. €

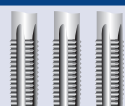

1ª
Calidad

2ª
Calidad

		Nº1	20 x 7	25 x 9	30 x 11		492,90	427,30
D644	UNF 1/4 - 5/16 - 3/8 - 7/16 - 1/2	Nº2	38 x 10			TC1		
D669	UNF 1/4-5/16 -3/8 -7/16 -1/2 -5/8 -3/4	Nº1 Nº3	38 x 10	45 x 14	30 x 11	-	929,00	817,14
D645	UNF 1/4 - 5/16 - 3/8 - 7/16 - 1/2 - 5/8 3/4 - 7/8 - 1"	Nº1 Nº4	38 x 10	45 x 14	55 x 16	-	1.139,14	1.032,86

**UNC
UNF**

HSS



Ref. **D670**

CONTENIDO

P.V.P. €

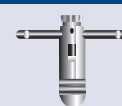
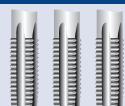

1ª
Calidad

2ª
Calidad

		Nº1	20 x 7	25 x 9	30 x 11		1.717,25	1.510,48
D670	UNC 1/4 - 5/16 -3/8 -7/16 -1/2 - 5/8 - 3/4 UNF 1/4 - 5/16 -3/8 -7/16 -1/2 - 5/8 - 3/4	Nº1 Nº3	38 x 14	45 x 18	30 x 11	-		

JUEGOS DE MACHOS DE MANO HSS y TIN EN ESTUCHES METÁLICOS



Ref. **JMB0**



Ref. **JMB2**



Ref. **JMBT2**

CONTENIDO						P.V.P. €	P.V.P. €	
						HSS		
JMB2	M3 - M4 - M5 - M6 M8 - M10 - M12	-	-	-	-	166,75	JMBT2	324,60
JMB0	M3 - M4 - M5 - M6 M8 - M10 - M12	2.5 / 3.3 / 4.2 / 5.0 6.8 / 8.5 / 10.2 mm	-	-	-	190,21	JMBT0	364,26*
JMB1	M3 - M4 - M5 - M6 M8 - M10 - M12	2.5 / 3.3 / 4.2 / 5.0 6.8 / 8.5 / 10.2 mm	Nº 1.1/2	-	-	200,70	JMBT1	312,14*
JMB5	M3 - M4 - M5 - M6 M8 - M10 - M12	2.5 / 3.3 / 4.2 / 5.0 6.8 / 8.5 / 10.2 mm	Nº 1.1/2	TC1	-	213,17	JMBT5	327,07*
JMBI2 (Izq)	M3 - M4 - M5 - M6 M8 - M10 - M12	-	-	-	-	303,17	JMBIT2	563,88
JMBI0 (Izq)	M3 - M4 - M5 - M6 M8 - M10 - M12	2.5 / 3.3 / 4.2 / 5.0 6.8 / 8.5 / 10.2 mm	-	-	-	351,21	JMBIT0	611,61*
JMBI1 (Izq)	M3 - M4 - M5 - M6 M8 - M10 - M12	2.5 / 3.3 / 4.2 / 5.0 6.8 / 8.5 / 10.2 mm	Nº 1.1/2	-	-	364,91	JMBIT1	624,28

MACHOS TERCEROS DE MANO HSS y TIN EN ESTUCHES METÁLICOS



Ref. **JMB3**



Ref. **JMB4**

CONTENIDO						P.V.P. €	P.V.P. €	
						HSS		
JMB3	M3 - M4 - M5 - M6 M8 - M10 - M12	-	-	-	-	75,05	JMBT3	93,98
JMB4	M3 - M4 - M5 - M6 M8 - M10 - M12	2.5 / 3.3 / 4.2 / 5.0 6.8 / 8.5 / 10.2 mm	-	-	-	93,40	JMBT4	124,16*
JMB7	M3 - M4 - M5 - M6 M8 - M10 - M12	2.5 / 3.3 / 4.2 / 5.0 6.8 / 8.5 / 10.2 mm	Nº 1.1/2	-	-	161,97	JMBT7	264,06*
JMB6	M3 - M4 - M5 - M6 M8 - M10 - M12	2.5 / 3.3 / 4.2 / 5.0 6.8 / 8.5 / 10.2 mm	Nº 1.1/2	TC1	-	178,09	JMBT6	279,02*
JMBI3 (Izq)	M3 - M4 - M5 - M6 M8 - M10 - M12	-	-	-	-	101,04	JMBIT3	187,95
JMBI4 (Izq)	M3 - M4 - M5 - M6 M8 - M10 - M12	2.5 / 3.3 / 4.2 / 5.0 6.8 / 8.5 / 10.2 mm	-	-	-	135,40	JMBIT4	249,14

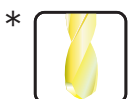

MACHOS DE MANO HSS-Co EN ESTUCHES METÁLICOS



Ref. **JMBX0**

CONTENIDO					P.V.P. €
INOX					HSS-Co 5%
JMBX0	M3 - M4 - M5 - M6 M8 - M10 - M12	2.5 / 3.3 / 4.2 / 5.0 6.8 / 8.5 / 10.2 mm	-	-	257,70
JMBX1	M3 - M4 - M5 - M6 M8 - M10 - M12	2.5 / 3.3 / 4.2 / 5.0 6.8 / 8.5 / 10.2 mm	Nº 1.1/2	-	271,21
JMBX2	M3 - M4 - M5 - M6 M8 - M10 - M12	-	-	-	243,68

CONTENIDO					P.V.P. €
1200 N/mm²					HSS-Co 5%
JMBMD0	M3 - M4 - M5 - M6 M8 - M10 - M12	2.5 / 3.3 / 4.2 / 5.0 6.8 / 8.5 / 10.2 mm	-	-	269,12
JMBMD1	M3 - M4 - M5 - M6 M8 - M10 - M12	2.5 / 3.3 / 4.2 / 5.0 6.8 / 8.5 / 10.2 mm	Nº 1.1/2	-	283,12
JMBMD2	M3 - M4 - M5 - M6 M8 - M10 - M12	-	-	-	256,53

ESTUCHES DE COJINETES EN CAJAS METÁLICAS HSS



Ref. **C5B3**

CONTENIDO			P.V.P. €
			HSS
C5B3	M3 - M4 - M5 - M6 - M8 - M10 - M12	-	182,45
C5B31 (Izq)	M3 - M4 - M5 - M6 - M8 - M10 - M12	-	364,91

TERRAJAS DE ROSCAR A MANO HEXAGONALES HSS

M

HSS

DIN
382

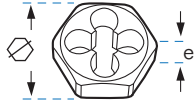

			C5HM
		Hex x e	€
M	3 x 0,35	18 x 5	31,86
M	3 x 0,50	19 x 5	31,86
M	3,5 x 0,60	18 x 5	31,86
M	4 x 0,50	18 x 5	31,86
M	4 x 0,70	19 x 5	31,86
M	5 x 0,50	18 x 5	31,86
M	5 x 0,75	18 x 5	31,86
M	5 x 0,80	19 x 7	31,86
M	6 x 0,75	18 x 7	31,86
M	6 x 1,00	19 x 7	31,86
M	7 x 0,75	21 x 9	33,86
M	7 x 1,00	21 x 9	33,86
M	8 x 0,75	21 x 9	33,86
M	8 x 1,00	21 x 9	33,86
M	8 x 1,25	22 x 9	33,86
M	9 x 0,75	21 x 9	39,86
M	9 x 1,00	21 x 9	39,86
M	9 x 1,25	22 x 9	39,86
M	10 x 1,00	27 x 11	39,86
M	10 x 1,25	27 x 11	39,86
M	10 x 1,50	27 x 11	39,86
M	11 x 1,00	27 x 11	66,42
M	11 x 1,50	27 x 11	66,42
M	12 x 1,25	36 x 10	66,42
M	12 x 1,50	36 x 10	66,42
M	12 x 1,75	36 x 10	55,81
M	14 x 1,25	36 x 14	75,48
M	14 x 1,50	36 x 10	75,48
M	14 x 2,00	36 x 10	55,81
M	15 x 1,00	36 x 14	87,54
M	15 x 1,50	41 x 14	87,54
M	16 x 1,00	41 x 14	87,54
M	16 x 1,50	41 x 14	87,54

			C5HM
		Hex x e	€
M	16 x 2,00	41 x 18	87,54
M	18 x 1,00	41 x 14	87,54
M	18 x 1,50	41 x 14	87,54
M	18 x 2,50	41 x 18	87,54
M	20 x 1,00	41 x 14	87,54
M	20 x 1,50	41 x 14	87,54
M	20 x 2,00	41 x 18	87,54
M	20 x 2,50	41 x 18	87,54
M	22 x 1,00	50 x 16	110,69
M	22 x 1,50	50 x 16	110,69
M	22 x 2,00	50 x 16	110,69
M	22 x 2,50	50 x 16	110,69
M	24 x 1,00	50 x 16	178,62
M	24 x 1,50	50 x 16	178,62
M	24 x 2,00	50 x 16	178,62
M	24 x 3,00	50 x 22	110,69
M	27 x 1,50	60 x 18	149,66
M	27 x 2,00	60 x 18	149,66
M	27 x 3,00	60 x 25	124,72
M	30 x 1,00	60 x 18	149,66
M	30 x 1,50	60 x 18	149,66
M	30 x 2,00	60 x 18	149,66
M	30 x 3,00	60 x 18	149,66
M	30 x 3,50	60 x 25	124,72
M	33 x 1,50	60 x 18	167,58
M	33 x 2,00	60 x 18	167,58
M	33 x 3,50	60 x 25	139,65
M	35 x 1,50	60 x 18	172,76
M	36 x 1,50	60 x 18	172,76
M	36 x 2,00	60 x 18	172,76
M	36 x 3,00	60 x 18	172,76
M	36 x 4,00	60 x 25	143,97

BSW

HSS

DIN
382

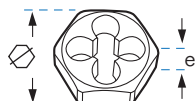

			C5HW
		Hex x e	€
BSW	1/8 x 40h.	19 x 5	39,86
BSW	3/16 x 24h.	19 x 7	39,86
BSW	1/4 x 20h.	19 x 7	39,86
BSW	5/16 x 18h.	22 x 9	41,84
BSW	3/8 x 16h.	27 x 11	49,81
BSW	7/16 x 14h.	27 x 11	49,81
BSW	1/2 x 12h.	36 x 14	59,80

			C5HW
		Hex x e	€
BSW	9/16 x 12h.	36 x 14	59,80
BSW	5/8 x 11h.	41 x 18	88,37
BSW	3/4 x 10h.	41 x 18	88,37
BSW	7/8 x 9h.	50 x 22	129,51
BSW	1" x 8h.	50 x 22	129,51
BSW	1.1/8 x 7h.	60 x 25	223,23

TERRAJAS DE ROSCAR A MANO HEXAGONALES HSS

**BSP
(GAS)**

HSS

DIN
382

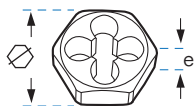

			C5HG
		Hex x e	€
G	1/8 x 28h.	27 x 11	70,16
G	1/4 x 19h.	36 x 10	70,16
G	3/8 x 19h.	41 x 14	87,73
G	1/2 x 14h.	41 x 14	87,73
G	5/8 x 14h.	50 x 16	206,56
G	3/4 x 14h.	50 x 16	206,56

			C5HG
		Hex x e	€
G	7/8 x 14h.	60 x 18	208,40
G	1" x 11h.	60 x 18	208,40
G	1.1/4 x 11h.	70 x 20	277,86
G	1.1/2 x 11h.	85 x 22	468,78
G	2" x 11h.	100 x 22	705,40

UNC

HSS

DIN
382

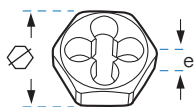

			C5HNC
		Hex x e	€
UNC	1/4-20h	18 x 7	29,05
UNC	5/16-18h	21 x 9	36,16
UNC	3/8-16h	27 x 11	43,64
UNC	7/16-14h	27 x 11	64,40
UNC	1/2-13h	36 x 14	64,64
UNC	9/16-12h	36 x 14	77,24

			C5HNC
		Hex x e	€
UNC	5/8-11h	41 x 18	59,85
UNC	3/4-10h	41 x 18	95,20
UNC	7/8-9h	50 x 22	135,10
UNC	1"-8h	50 x 22	135,10
UNC	1.1/8-7h	60 x 25	178,62
UNC	1.1/4-7h	60 x 25	178,62

UNF

HSS

DIN
382

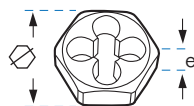

			C5HNF
		Hex x e	€
UNF	1/4-28h.	18 x 7	30,80
UNF	5/16-24h.	21 x 9	38,50
UNF	3/8-24h.	27 x 11	46,32
UNF	7/16-20h.	27 x 11	68,25
UNF	1/2-20h.	36 x 10	69,30
UNF	9/16-18h.	36 x 10	77,24
UNF	5/8-18h.	41 x 14	96,37

			C5HNF
		Hex x e	€
UNF	3/4-16h.	41 x 14	100,92
UNF	7/8-14h.	50 x 16	127,64
UNF	1"-12h.	50 x 16	133,81
UNF	1"-14h.	50 x 16	133,81
UNF	1.1/8-12h.	60 x 18	178,62
UNF	1.1/4-12h.	60 x 18	178,62

GALGAS PARA LA COMPROBACIÓN DE PASOS DE ROSCAS



		RANGO DE PASOS		GAM
TIPOS DE ROSCA		Métricos	Ingleses	€
GAM	Pasos rosca métrica	0,25 - 2,5		9,01
GAMW	Pasos rosca métrica /rosca Inglesa	0,25 - 6,0	62h - 4h	15,25

ALARGADORES DE MACHOS

DIN 377

DIN 10

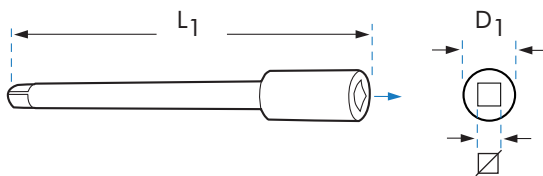

	AL		
∅ x L ₁ mm	D ₁ mm	€	
AL21	2,1 x 60	6,0	6,51
AL24	2,4 x 70	6,0	6,51
AL27	2,7 x 80	7,0	6,51
AL30	3,0 x 90	7,0	6,51
AL34	3,4 x 95	8,0	7,00
AL38	3,8 x 95	9,0	7,34
AL43	4,3 x 105	10,0	8,13
AL49	4,9 x 110	11,0	8,16
AL55	5,5 x 115	12,0	8,37

	AL		
∅ x L ₁ mm	D ₁ mm	€	
AL62	6,2 x 120	14,0	10,47
AL70	7,0 x 125	15,0	10,91
AL80	8,0 x 125	17,0	12,99
AL90	9,0 x 135	19,0	14,27
AL100	10,0 x 140	21,0	18,60
AL110	11,0 x 150	23,0	20,00
AL120	12,0 x 160	25,0	21,53
AL130	13,0 x 165	27,0	32,09
AL145	14,5 x 175	29,0	34,16

	AL		
∅ x L ₁ mm	D ₁ mm	€	
AL160	16,0 x 185	30,0	36,14
AL180	18,0 x 195	33,0	41,18
AL200	20,0 x 220	36,0	54,92
AL220	22,0 x 220	40,0	80,27
AL240	24,0 x 235	42,0	98,72
AL260	26,0 x 245	45,0	114,83
AL290	29,0 x 260	55,0	149,77
AL320	32,0 x 280	55,0	195,45

ADAPTADORES UNIVERSALES PARA COJINETES

ADAPTADOR COJINETE REDONDO A HEXAGONAL

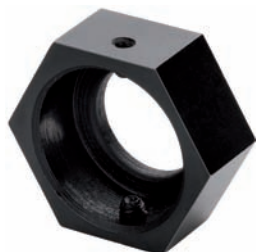
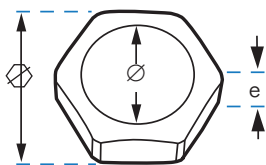

			PC5H
	∅ mm	∅ x e	€
PC5HX20	20	26 x 10	9,44
PC5HX25	25	32 x 14	11,16
PC5HX38	38	50 x 18	16,02
PC5HX50	50	62 x 20	22,71
PC5HX63	63	76 x 26	27,38
PC5HX75	75	89 x 28	40,56

ADAPTADOR PARA COJINETES DE MÁQUINA

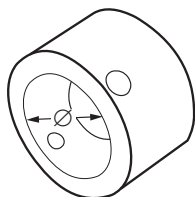

		PC5
	∅ mm	€
PC5X20	20	23,02
PC5X25	25	29,69

CASQUILLO AUMENTADOR PARA COJINETES

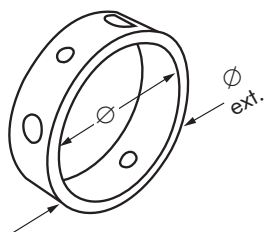

			PC5
	∅ mm	∅ ext.	€
PC520X25	20	25	16,33
PC520X30	20	30	17,97
PC520X30	25	30	17,97
PC525X38	25	38	19,60
PC530X38	30	38	19,60
PC530X45	30	45	22,87
PC538X45	38	45	22,87

PORTA HERRAMIENTAS DE ACERO (ROBUSTOS, SIN ROTURAS)

Ref. **GA**

DIN
1814



GA

Nº NUEVA
NORMA

Nº 0	Nº 1	Nº 1.1/2	Nº 2	Nº 3	Nº 4	Nº 5	Nº 6	Nº 7	Nº 8
2,00-5,00	2,00-6,30	2,50-8,00	4,00-9,00	4,90-12,00	5,50-16,00	7,00-20,00	9,00-24,00	16,00-32,00	20,00-35,00
€ 14,14	€ 14,94	€ 15,87	€ 20,06	€ 28,39	€ 45,40	€ 96,08	€ 103,56	€ 163,21	€ 218,13

VOLVEDORES PARA TERRAJAS DE ROSCAR

Ref. **VA**

DIN
225



IMPORTANTE: A la hora de cursar sus pedidos de volvedores, indiquen el espesor del volvedor que corresponda, según detalle de espesores que indicamos en la tarifa de terrajas.

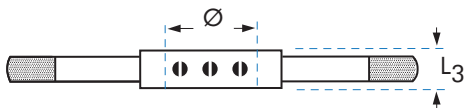

VA

Ø x L3 mm	16x5	20x5	20x7	25x9	30x11	38x10	38x14	45x14	45x18	55x16	55x22	65x18	65x25
€	7,84	8,51	8,51	9,73	11,78	15,40	15,38	18,90	19,05	24,44	25,59	35,02	35,02
Ø x L3 mm	75x20	75x30	90x22	90x36	105x22	105x36	120x22	120x36	130x25	130x36	140x25	140x36	
€	60,67	63,50	76,85	80,44	88,36	88,36	229,80	229,80	238,90	238,90	251,22	251,22	

Ref. **VA**

PULGADAS



VA

Ø mm	20,60	25,40	38,10	44,40	50,80	63,50
PULGADAS	13/16"	1"	1.1/2"	1.3/4"	2"	2.1/2"
€	8,51	10,10	15,11	19,05	22,42	34,34

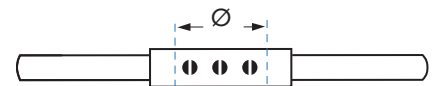

NOTA: Los volvedores para terrajas en Ø exteriores en pulgadas, están en desuso.

EXPOSITOR DE METACRILATO



Dimensiones: 500 x 320 x 110 mm

CONTENIDO

P.V.P. €

GV-01	Nº 1.1/2 5	Nº 2 5	20 x 5 5	20 x 7 5	25 x 9 5	30 x 11 5	38 x 14 5	TC1 4	TC2 4	602,38
-------	---------------	-----------	-------------	-------------	-------------	--------------	--------------	----------	----------	--------

GIRAMACHOS EN T CON CRIQUE

Portaherramientas

Rosa

Ref. **TC** **TIPO T** **1ª Calidad**  TIPO CORTO

	TC					
	CAPACIDAD mm mín.-máx.	Para mangos de machos DIN		L ₁ mm	PESO g	€
TC3B	2,6 - 5,5	M3 - 8	M3 - 6	85	180	20,42
TC4B	4,6 - 8,0	M5 - 12	M6 - 12	110	300	27,33



Ref. **TL** **TIPO T** **1ª Calidad** TIPO LARGO

	TL					
	CAPACIDAD mm mín.-máx.	Para mangos de machos DIN		L ₁ mm	PESO g	€
TL3	2,6 - 5,5	M3 - 8	M3 - 6	250	250	32,07
TL4	4,6 - 8,0	M5 - 12	M6 - 12	300	440	38,17



Ref. **TC** **TIPO T** **2ª Calidad**  TIPO CORTO

	TC					
	CAPACIDAD mm mín.-máx.	Para mangos de machos DIN		L ₁ mm	PESO g	€
TC1B	2,6 - 5,5	M3 - 8	M3 - 6	85	180	14,61
TC2B	4,6 - 8,0	M5 - 12	M6 - 12	110	300	19,59



Ref. **TL** **TIPO T** **2ª Calidad** TIPO LARGO

	TL					
	CAPACIDAD mm mín.-máx.	Para mangos de machos DIN		L ₁ mm	PESO g	€
TL1	2,6 - 5,5	M3 - 10	M3 - 6	250	250	24,03
TL2	4,6 - 8,0	M5 - 12	M6 - 12	300	440	28,64



EXTRACTORES DE MACHOS ROTOS PARA MACHOS DE CANALES RECTOS - NO HELICOIDALES



EXTRACTORES SUELTOS

Ø MACHO A EXTRAER		MACHOS DE MANO	MACHOS DE MÁQUINA	€/ Ud.
BSW UNC	M			EXTRACTOR COMPLETO
--	M3		10.043	34,80
1/8	M3,2		10.053	34,80
--	M3,5		10.063	34,80
5/32	M4		10.083	34,80
3/16	M5		10.103	34,80
--	M5,5	10.124	10.103	34,80
1/4	M6		10.253	35,82
5/16	M8	10.314	10.313	37,53
--	M9	10.374	10.373	37,17
3/8	M10	10.404	10.373	37,17
7/16	M11	10.434	10.433	39,24
1/2	M12	10.504	10.503	41,96
9/16	M14	10.564	10.563	57,99
5/8	M16	10.624	10.623	63,12
--	M18	10.684	10.753	76,71
3/4	M20	10.754	10.753	76,71
7/8	M22	10.874	10.873	83,93
1"	M25	11.004	11.003	93,61

VARILLA REPUESTO

MACHOS DE MANO	MACHOS DE MÁQUINA	€/ Ud.
		VARILLA EXTRA
	12.043	1,81
	12.053	1,81
	12.063	1,81
	12.083	1,81
	12.103	2,71
	12.123	2,71
	12.253	3,30
12.314	12.313	3,72
12.374		3,72
12.404	12.373	3,85
12.434	12.433	3,90
12.504	12.503	4,91
12.564	12.563	5,49
12.624	12.623	7,01
12.684		7,01
12.754	12.753	7,42
12.874	12.873	9,62
13.004	13.003	16,01

3 SIMPLES PASOS PARA EXTRAER MACHOS DE ROSCAR ROTOS DE CANALES RECTOS

Sacar toda la viruta del macho roto. Introducir las varillas del extractor en los canales del macho roto con firmeza hasta el fondo.



Empujar el soporte hacia abajo, hasta tocar el macho roto. Deslice el casquillo hacia abajo, hasta tocar la zona de trabajo.



Aplicar al cuadradillo del extractor un gira-machos. Gire a izquierdas unas cuantas veces hasta soltarlo y entonces saque el macho roto.



JUEGOS DE EXTRACTORES PARA MACHOS ROTOS (Canales rectos)



	MEDIDAS INCLUIDAS PARA MACHOS DE MÁQUINA: 3 y 4 CANALES	P.V.P. €
18.001.3	M5- M6- M8- M10- M11- M12 3/16 - 1/4 - 5/16 - 3/8 - 7/16 - 1/2	236,61
18.002.3	M6- M8 -M10- M11- M12- M16 1/4 - 5/16 - 3/8 - 7/16 - 1/2 - 5/8	266,20
18.015.3	M3- M3,2- M3,5- M4-M5- M5,50- M6- M8 M9- M10- M12- M16- M18- M22- M25	744,64

MACHOS PARA ROSCAR A MÁQUINA HSS-Co

M
MF

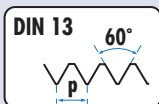

HSS-Co
5%

TOL
6H

Vc
12 m/min

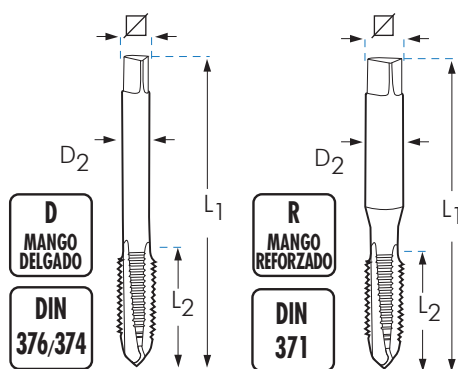

 	 	$L_1 \times L_2 \times D_2 \times \square$ mm	M1D	M2D	M3D	M4D	M1R	M2R	M3R	M4R	
			FORMA C	FORMA B	15°	35°	FORMA C	FORMA B	15°	35°	
			€	€	€	€	€	€	€	€	
M	1x0,25	0,75	R 40 x 6 x 2,5 x 2,1					29,50			
M	1,1x0,25	0,85	R 40 x 6 x 2,5 x 2,1					28,70			
M	1,2x0,25	0,95	R 40 x 6 x 2,5 x 2,1					27,22			
M	1,4x0,30	1,10	R 40 x 7 x 2,5 x 2,1					27,22			
M	1,6x0,35	1,25	R 40 x 8 x 2,5 x 2,1					26,74			
M	1,7x0,35	1,35	R 40 x 8 x 2,5 x 2,1					25,75			
M	1,8x0,35	1,45	R 40 x 8 x 2,5 x 2,1					25,12			
M	2x0,40	1,60	R 40 x 9 x 2,8 x 2,1					11,67	12,80	15,25	14,85
M	2,2x0,45	1,75	R 40 x 9 x 2,8 x 2,1					13,07			
M	2,3x0,40	1,90	R 40 x 9 x 2,8 x 2,1					12,04			
M	2,5x0,45	2,05	R 50 x 9 x 2,8 x 2,1					11,67	12,80	20,65	14,85
M	2,6x0,45	2,10	R 50 x 9 x 2,8 x 2,1					11,67	13,03		26,60
M	3x0,50	2,50	R 56 x 11 x 3,5 x 2,7 D 56 x 11 x 2,2 x 1,8	8,31	9,32	12,00	11,23	8,31*	8,82	11,89	11,34
M	3x0,60	2,40	R 56 x 11 x 3,5 x 2,7					14,24	15,97		20,71
M	3,5x0,60	2,90	R 56 x 12 x 4,0 x 3,0 D 56 x 12 x 2,5 x 2,1					11,23	12,02	14,81	14,86
M	3,5x0,75	2,75	R 56 x 12 x 4,0 x 3,0					14,82			
M	4x0,50	3,50	R 63 x 13 x 4,5 x 3,4 D 63 x 13 x 2,8 x 2,1	16,76	19,12		21,20	16,76	18,46		21,79
M	4x0,70	3,30	R 63 x 13 x 4,5 x 3,4 D 63 x 13 x 2,8 x 2,1	8,47	9,51	12,01	11,24	8,63*	9,34	11,90	11,35
M	4x0,75	3,25	R 63 x 13 x 4,5 x 3,4					12,27	14,00		
M	4x0,80	3,20	R 63 x 13 x 4,5 x 3,4					65,16			
M	4,5x0,50	4,00	R 70 x 14 x 6,0 x 4,9						21,49		
M	4,5x0,75	3,75	R 70 x 14 x 6,0 x 4,9					15,18	17,19		
M	5x0,50	4,50	R 70 x 14 x 6,0 x 4,9 D 70 x 11 x 3,5 x 2,7	17,26	19,65		21,43	17,26*	18,97		23,25
M	5x0,75	4,50	R 74 x 14 x 6,0 x 4,9 D 70 x 16 x 3,5 x 2,7					15,48	17,99		23,10
M	5x0,80	4,20	R 70 x 16 x 6,0 x 4,9 D 70 x 16 x 3,5 x 2,7	8,47	9,51	11,51	10,78	8,63	9,52	11,41	10,99
M	5x0,90	4,10	R 70 x 15 x 6,0 x 4,9 D 70 x 16 x 3,5 x 2,7					12,97	17,18		
M	5x1,00	4,00	R 72 x 17 x 6,0 x 4,9					34,74			
M	5,5x0,90	4,60	R 80 x 17 x 6,0 x 4,9					34,74			
M	6x0,50	5,50	R 80 x 17 x 6,0 x 4,9 D 80 x 13 x 4,5 x 3,4	20,44	25,97		33,08	21,77			
M	6x0,75	5,25	R 80 x 13 x 6,0 x 4,9 D 80 x 13 x 4,5 x 3,4	13,46	16,32		19,05	14,09	16,90		20,67
M	6x1,00	5,00	R 80 x 17 x 6,0 x 4,9 D 80 x 17 x 4,5 x 3,4	9,65	10,42	12,52	11,82	9,83*	10,24	12,52	11,94

* Disponibles también con rosca izquierda con 100% de recargo sobre los precios tarifados en rosca derecha

MACHOS PARA ROSCAR A MÁQUINA HSS-Co

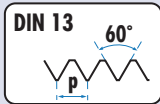

HSS-Co
5%

TOL
6H

D
MANGO
DELGADO

DIN
376,374

Vc
12 m/min

R
MANGO
REFORZADO

DIN
371

	L ₁ x L ₂ x D ₂ x ∅ mm	M1D	M2D	M3D	M4D	M1R	M2R	M3R	M4R
M 6x1,25	4,75	R 80 x 17 x 6,0 x 4,9				34,14			
M 7x0,75	6,25	D 80 x 13 x 5,5 x 4,3	17,96	20,12	25,55				
M 7x1,00	6,00	R 80 x 17 x 7,0 x 5,5 D 80 x 17 x 5,5 x 4,3	12,07	13,94	15,62	15,60	11,84*	13,94	15,62
M 8x0,50	7,50	D 80 x 13 x 6 x 4,9	23,54						
M 8x0,75	7,25	D 80 x 13 x 6 x 4,9	16,43	20,14		27,64			
M 8x1,00	7,00	D 90 x 20 x 6 x 4,9	13,94	16,01	19,15	17,73			
M 8x1,25	6,75	R 90 x 20 x 8 x 6,2 D 90 x 20 x 6 x 4,9	10,83	11,70	15,05	13,94	11,04*	11,49	15,05
M 8x1,50	6,50	D 90 x 20 x 6 x 4,9	68,86						
M 9x1,00	8,00	D 90 x 20 x 7 x 5,5	20,32	22,50		24,60			
M 9x1,25	7,80	R 90 x 20 x 9 x 7,0 D 90 x 20 x 7 x 5,5	16,92	18,46	21,53	22,06	17,07	18,46	22,10
M 10x0,50	9,50	D 90 x 20 x 7 x 5,5	68,22						
M 10x0,75	9,25	D 90 x 16 x 7 x 5,5	25,09	27,04		33,88			
M 10x1,00	9,00	D 90 x 16 x 7 x 5,5	15,44	17,79	22,61	21,78			
M 10x1,25	8,80	D 100 x 22 x 7 x 5,5	17,68	21,27	24,64	23,74			
M 10x1,50	8,50	R 100 x 22 x 10 x 8,0 D 100 x 22 x 7 x 5,5	12,47	14,42	17,73	16,53	12,35*	14,36	17,73
M 11x0,75	10,25	D 90 x 20 x 8 x 6,2							
M 11x1,00	10,00	D 90 x 20 x 8 x 6,2	25,69	28,53	72,14	67,53			
M 11x1,25	9,75	D 100 x 22 x 8 x 6,2	27,45	30,50	72,14	60,27			
M 11x1,50	9,50	D 100 x 22 x 8 x 6,2	21,43	24,01	52,60	49,21			
M 12x0,75	11,25	D 100 x 22 x 9 x 7,0	42,04						
M 12x1,00	11,00	D 100 x 22 x 9 x 7,0	21,01	23,37	27,89	26,87			
M 12x1,25	10,75	D 100 x 22 x 9 x 7,0	21,26	23,62	26,70	25,73			
M 12x1,50	10,50	D 100 x 22 x 9 x 7,0	19,00*	21,07	25,68	24,74			
M 12x1,75	10,20	D 100 x 24 x 9 x 7,0	15,43*	17,88	23,77	21,51			
M 13x0,75	12,25	D 100 x 22 x 11 x 9,0	73,36						
M 13x1,00	12,00	D 100 x 22 x 11 x 9,0	38,85	44,00					
M 13x1,25	11,75	D 100 x 22 x 11 x 9,0	38,85	44,00					
M 13x1,50	11,50	D 100 x 22 x 11 x 9,0	38,85	44,00					
M 13x1,75	11,25	D 100 x 22 x 11 x 9,0	37,15	44,00					
M 14x0,75	13,25	D 100 x 22 x 11 x 9,0	73,36						
M 14x1,00	13,00	D 100 x 22 x 11 x 9,0	32,56	35,82	43,00	43,04			
M 14x1,25	12,80	D 100 x 22 x 11 x 9,0	28,78	31,41	39,44	38,00			
M 14x1,50	12,50	D 100 x 22 x 11 x 9,0	22,64*	24,94	31,10	29,96			
M 14x2,00	12,00	D 110 x 26 x 11 x 9,0	22,49*	24,98	28,95	28,14			
M 15x1,00	14,00	D 100 x 22 x 12 x 9,0	43,00	47,18		58,40			
M 15x1,25	13,75	D 100 x 22 x 12 x 9,0	47,74	51,68					
M 15x1,50	13,50	D 100 x 22 x 12 x 9,0	38,15	41,98	107,04	91,02			
M 15x2,00	13,00	D 110 x 27 x 11 x 9,0	46,70	51,39					
M 16x1,00	15,00	D 100 x 22 x 12 x 9,0	40,52	44,57	60,20	59,00			
M 16x1,25	14,75	D 100 x 22 x 12 x 9,0	44,94	49,41	66,94	65,43			
M 16x1,50	14,50	D 100 x 22 x 12 x 9,0	26,77*	31,19	38,76	37,34			
M 16x2,00	14,00	D 110 x 27 x 12 x 9,0	26,46*	29,22	34,98	34,00			
M 17x1,00	16,00	D 100 x 22 x 12 x 9,0	83,57						
M 17x1,25	15,75	D 100 x 22 x 12 x 9,0	83,57						
M 17x1,50	15,50	D 100 x 22 x 12 x 9,0	83,57						
M 18x1,00	17,00	D 110 x 25 x 14 x 11,0	45,38	49,88		72,20			
M 18x1,25	16,75	D 110 x 25 x 14 x 11,0	58,30						
M 18x1,50	16,50	D 110 x 25 x 14 x 11,0	35,43*	38,99	47,62	45,13			
M 18x2,00	16,00	D 125 x 30 x 14 x 11,0	46,40	53,86	94,23	88,17			

* Disponibles también con rosca izquierda con 100% de recargo sobre los precios tarifados en rosca derecha

MACHOS PARA ROSCAR A MÁQUINA HSS-Co

**M
MF**

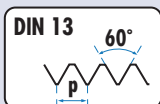

**HSS-Co
5%**

**TOL
6H**

**Vc
12 m/min**

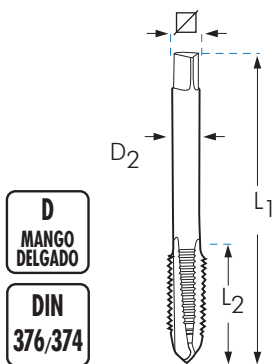

**D
MANGO
DELGADO**

**DIN
376/374**



	L ₁ x L ₂ x D ₂ x ∅ mm	M1D	M2D	M3D	M4D	
		FORMA C €	FORMA B €	15° €	35° €	
M 18x2,50	15,50	D 125 x 30 x 14 x 11,0	38,07*	41,63	47,09	45,77
M 19x1,00	18,00	D 110 x 22 x 14 x 11,0	109,80			
M 19x1,25	17,75	D 110 x 25 x 14 x 11,0	108,74			
M 19x1,50	17,50	D 110 x 25 x 14 x 11,0	107,77			
M 19x2,00	17,00	D 110 x 25 x 14 x 11,0				
M 20x1,00	19,00	D 125 x 25 x 16 x 12,0	59,92	66,53		77,11
M 20x1,25	18,75	D 125 x 25 x 16 x 12,0	109,80			
M 20x1,50	18,50	D 125 x 25 x 16 x 12,0	40,13*	44,10	53,52	51,56
M 20x2,00	18,00	D 140 x 32 x 16 x 12,0	52,60	57,83		68,79
M 20x2,50	17,50	D 140 x 32 x 16 x 12,0	40,52*	44,94	50,26	48,86
M 21x1,00	20,00	D 125 x 25 x 16 x 12,0	159,42			
M 21x1,25	19,75	D 125 x 25 x 16 x 12,0	159,42			
M 21x1,50	19,50	D 125 x 25 x 16 x 12,0	152,24			
M 22x1,00	21,00	D 125 x 25 x 18 x 14,5	67,17	73,88		99,37
M 22x1,25	20,75	D 125 x 25 x 18 x 14,5	109,80			
M 22x1,50	20,50	D 125 x 25 x 18 x 14,5	48,31	53,14	58,71	53,81
M 22x2,00	20,00	D 140 x 32 x 18 x 14,5	67,17	73,88		99,37
M 22x2,50	19,50	D 140 x 32 x 18 x 14,5	49,05*	53,93	61,78	59,55
M 23x1,00	22,00	D 125 x 25 x 18 x 14,5	154,99			
M 23x1,50	21,50	D 125 x 25 x 18 x 14,5	154,99			
M 24x1,00	23,00	D 140 x 25 x 18 x 14,5	73,19	92,02		104,99
M 24x1,25	22,75	D 140 x 25 x 18 x 14,5	159,42			
M 24x1,50	22,50	D 140 x 28 x 18 x 14,5	59,41	65,32	78,48	75,60
M 24x2,00	22,00	D 140 x 28 x 18 x 14,5	75,79*	82,58		95,01
M 24x3,00	21,00	D 160 x 34 x 18 x 14,5	58,71*	64,25	74,46	72,38
M 25x1,00	24,00	D 140 x 28 x 18 x 14,5	136,46			
M 25x1,25	23,75	D 140 x 28 x 18 x 14,5	215,63			
M 25x1,50	23,50	D 140 x 28 x 18 x 14,5	92,43	101,39		
M 25x2,00	23,00	D 140 x 28 x 18 x 14,5	206,22	226,85		
M 26x1,00	25,00	D 140 x 28 x 18 x 14,5	105,94			
M 26x1,50	24,50	D 140 x 28 x 18 x 14,5	80,11	83,98	147,02	135,52
M 26x2,00	24,00	D 140 x 28 x 18 x 14,5	206,22	226,85		95,01
M 27x1,00	26,00	D 140 x 28 x 20 x 16,0	102,25	127,14		
M 27x1,50	25,50	D 140 x 28 x 20 x 16,0	87,48	96,04	213,66	201,95
M 27x2,00	25,00	D 140 x 28 x 20 x 16,0	104,20*	114,49		

* Disponibles también con rosca izquierda con 100% de recargo sobre los precios tarifados en rosca derecha

MACHOS PARA ROSCAR A MÁQUINA HSS-Co

M
MF

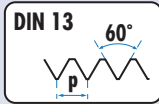

HSS-Co
5%

TOL
6H

D
MANGO
DELGADO

DIN
376/374

Vc
12 m/min

		L ₁ x L ₂ x D ₂ x \square mm	M1D	M2D	M3D	M4D
			FORMA C €	FORMA B €	15° €	35° €
M 27x3,00	24,00	D 160 x 36 x 20 x 16	73,29*	80,36	91,62	89,06
M 28x1,00	27,00	D 140 x 28 x 20 x 16	206,22			
M 28x1,50	26,50	D 140 x 28 x 20 x 16	87,48	96,04	111,27	105,30
M 28x2,00	26,00	D 140 x 28 x 20 x 16	102,64	115,92	131,13	135,17
M 30x1,00	29,00	D 150 x 28 x 22 x 18	111,89	134,08		157,80
M 30x1,50	28,50	D 150 x 28 x 22 x 18	91,18	100,33	120,66	116,24
M 30x2,00	28,00	D 150 x 28 x 22 x 18	112,86*	124,14		166,97
M 30x3,00	27,00	D 150 x 28 x 22 x 18				
M 30x3,50	26,50	D 180 x 40 x 22 x 18	93,92*	103,26	117,42	114,13
M 32x1,00	31,00	D 150 x 28 x 22 x 18	264,79	281,16		
M 32x1,50	30,50	D 150 x 28 x 22 x 18	115,37	126,66	148,66	
M 32x2,00	30,00	D 150 x 28 x 22 x 18	136,34	208,77		
M 33x1,00	32,00	D 160 x 30 x 25 x 20	253,24			
M 33x1,50	31,50	D 160 x 30 x 25 x 20	125,17	137,86		161,65
M 33x2,00	31,00	D 160 x 30 x 25 x 20	213,04	234,28		267,70
M 33x3,50	29,50	D 180 x 40 x 25 x 20	112,86*	129,86		150,68
M 34x1,50	32,50	D 170 x 30 x 28 x 22	144,48	158,93		
M 34x2,00	32,00	D 160 x 30 x 25 x 20	315,52			
M 35x1,50	33,50	D 170 x 30 x 28 x 22	152,67	167,93		185,00
M 35x2,00	33,00	D 170 x 30 x 28 x 22	280,37	308,65		
M 36x1,50	34,50	D 170 x 30 x 28 x 22	144,48	164,80		200,97
M 36x2,00	34,00	D 170 x 30 x 28 x 22	195,14	214,65		
M 36x3,00	33,00	D 200 x 50 x 28 x 22	223,88	246,24		290,88
M 36x4,00	32,00	D 200 x 50 x 28 x 22	143,96*	158,69	191,03	184,50
M 38x1,50	36,50	D 170 x 30 x 28 x 22	154,02	173,54		
M 38x2,00	36,00	D 170 x 32 x 28 x 22	327,37	360,12		
M 39x1,50	37,50	D 170 x 32 x 32 x 24	242,02			
M 39x2,00	37,00	D 170 x 32 x 32 x 24	242,02			
M 39x3,00	36,00	D 200 x 47 x 32 x 24	316,07			
M 39x4,00	35,00	D 200 x 50 x 32 x 24	184,18	202,60		
M 40x1,50	38,50	D 170 x 30 x 32 x 24	201,39	221,66		
M 40x2,00	38,00	D 170 x 30 x 32 x 24	242,66			
M 40x3,00	37,00	D 200 x 47 x 32 x 24	237,92	283,85		
M 42x1,50	40,50	D 170 x 30 x 32 x 24	212,04	227,26		
M 42x2,00	40,00	D 170 x 30 x 32 x 24	277,61			
M 42x3,00	39,00	D 200 x 45 x 32 x 24	277,61	338,77		
M 42x4,50	37,50	D 200 x 56 x 32 x 24	236,83	260,45		
M 45x1,50	43,50	D 180 x 32 x 36 x 29	253,24	278,54		
M 45x2,00	43,00	D 180 x 32 x 36 x 29	321,43			
M 45x3,00	42,00	D 200 x 47 x 36 x 29	321,43			
M 45x4,50	40,50	D 220 x 58 x 36 x 29	258,70	284,56		
M 48x1,50	46,50	D 190 x 32 x 36 x 29	258,70			
M 48x2,00	46,00	D 190 x 32 x 36 x 29	388,41			
M 48x3,00	45,00	D 220 x 52 x 36 x 29	389,52			
M 48x5,00	43,00	D 250 x 65 x 36 x 29	318,13	349,92		
M 50x1,50	48,50	D 190 x 32 x 36 x 29	302,54			
M 52x1,50	50,50	D 190 x 32 x 40 x 32	306,30			
M 52x2,00	50,00	D 190 x 32 x 40 x 32	484,73			
M 52x3,00	49,00	D 225 x 50 x 40 x 32	498,17			
M 52x5,00	47,00	D 250 x 65 x 40 x 32	325,80	388,19		

* Disponibles también con rosca izquierda con 100% de recargo sobre los precios tarifados en rosca derecha

MACHOS PARA ROSCAR A MÁQUINA HSS-Co

BSW

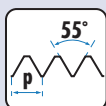

HSS-Co
5%

TOL
Clase 2

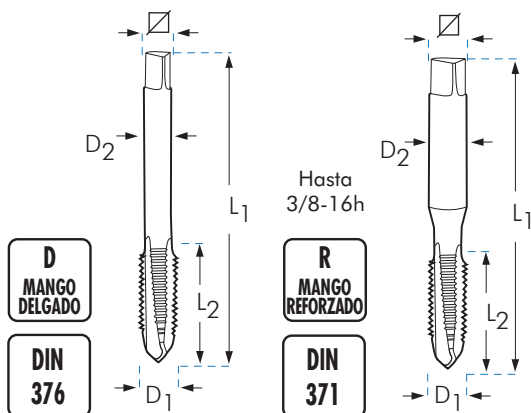

Vc
12 m/min



DIN 376	D1 mm	D	MANGO DELGADO	L1 x L2 x D2 x Ø	M1R	M2R	M3R	M4R
					FORMA C	FORMA B	15°	35°
					€	€	€	€
W 1/16-60h.	1,59	1,15	R	40 x 8 x 2,5 x 2,1				
W 3/32-48h.	2,38	1,80	R	50 x 9 x 2,8 x 2,1	16,70	17,95		
W 1/8-40h.	3,17	2,55	R	56 x 11 x 3,5 x 2,7	13,93*	15,40	17,49	17,49
W 5/32-32h.	3,97	3,10	R	63 x 13 x 4,5 x 3,4	13,93	15,40	17,49	17,49
W 3/16-24h.	4,76	3,60	R	70 x 15 x 6,0 x 4,9	16,39	15,40	17,49	17,49
W 7/32-24h.	5,56	4,40	R	80 x 16 x 6,0 x 4,9	21,16	23,40		
W 1/4-20h.	6,35	5,10	R	80 x 17 x 7,0 x 5,5	14,89	17,49	19,85	19,85
W 5/16-18h.	7,94	6,50	R	90 x 20 x 8,0 x 6,2	18,50	20,48	23,16	23,16
W 3/8-16h.	9,52	7,90	R	100 x 22 x 10,0 x 8,0	18,68	22,63	25,74	25,74

MANGO DELGADO				M1D	M2D	M3D	M4D	
W 7/16-14h.	11,11	9,25	D	100 x 22 x 8,0 x 6,2	27,17	29,05	33,99	33,99
W 1/2-12h.	12,70	10,50	D	110 x 24 x 9,0 x 7,0	26,06	28,59	32,57	32,57
W 9/16-12h.	14,29	12,00	D	110 x 26 x 11,0 x 9,0	37,35	41,11	46,70	46,70
W 5/8-11h.	15,87	13,40	D	110 x 27 x 12,0 x 9,0	35,37	38,85	44,16	44,16
W11/16-11h.	17,46	15,25	D	110 x 27 x 12,0 x 9,0				
W 3/4-10h.	19,05	16,50	D	125 x 30 x 14,0 x 11,0	47,32	52,07	59,17	59,17
W 7/8-9h.	22,22	19,25	D	140 x 32 x 18,0 x 14,5	64,10	70,47	80,09	80,09
W 1"-8h.	25,40	21,75	D	160 x 36 x 18,0 x 14,5	80,57	88,56	100,51	100,51
W 1.1/8-7h.	28,57	24,75	D	180 x 40 x 22,0 x 18,0	104,47	119,89	144,16	
W 1.1/4-7h.	31,75	27,75	D	180 x 40 x 22,0 x 18,0	151,77	174,20		
W 1.3/8-6h.	34,92	30,50	D	200 x 50 x 28,0 x 22,0	249,46	286,07		
W 1.1/2-6h.	38,10	33,50	D	200 x 50 x 32,0 x 24,0	270,77	310,79		
W 1.5/8-5h.	41,27	46,50	D	220 x 65 x 32,0 x 24,0	377,94	433,82		
W 1.3/4-5h.	44,45	39,00	D	220 x 58 x 36,0 x 29,0	407,72	468,01		
W1.7/8-4,5h.	47,62	42,00	D	250 x 75 x 36,0 x 29,0	452,02	518,84		
W 2"-4,5h.	50,80	44,50	D	250 x 65 x 40,0 x 32,0	583,53			
W 2.1/4-4h.	57,15	50,00						
W 2.1/2-4h.	63,50	56,50						
W2.3/4-3,5h.	69,85	62,00						
W 3"-3,5h.	76,20	68,00						

* Disponibles también con rosca izquierda con 100% de recargo sobre los precios tarifados en rosca derecha

MACHOS PARA ROSCAR A MÁQUINA HSS-Co

**BSP
(GAS)**

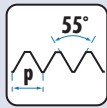

**HSS-Co
5%**

**TOL
ISO 228**

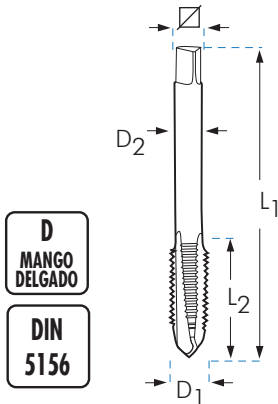

**Vc
12 m/min**



				M1D	M2D	M3D	M4D	
				FORMA C	FORMA B	15°	35°	
				€	€	€	€	
		D ₁ mm		L ₁ x L ₂ x D ₂ x ∅ mm				
G	1/8-28h.	9,728	8,80	D 90 x 16 x 7 x 5,5	23,14*	26,44	28,07	28,07
G	1/4-19h.	13,157	11,80	D 100 x 22 x 11 x 9,0	32,10*	35,34	40,30	40,30
G	3/8-19h.	16,662	15,25	D 100 x 22 x 12 x 9,0	38,43*	42,28	48,13	48,13
G	1/2-14h.	20,955	19,00	D 125 x 25 x 16 x 12,0	48,58	53,44	60,71	60,71
G	5/8-14h.	22,911	21,00	D 125 x 25 x 18 x 14,5	60,53	66,39	75,59	75,59
G	3/4-14h.	26,441	24,50	D 140 x 28 x 20 x 16,0	76,03	83,67	95,03	95,03
G	7/8-14h.	30,201	28,25	D 150 x 28 x 22 x 18,0	102,20	112,44	127,81	127,81
G	1"-11h.	33,249	30,75	D 160 x 30 x 25 x 20,0	118,00	129,78	145,92	145,92
G	1.1/8-11h.	37,897	35,50	D 170 x 30 x 28 x 22,0	188,43	214,97		236,10
G	1.1/4-11h.	41,910	39,50	D 170 x 30 x 32 x 24,0	221,10	243,31		269,35
G	1.3/8-11h.	44,323	42,00	D 180 x 32 x 36 x 29,0	276,51			374,14
G	1.1/2-11h.	47,803	45,25	D 190 x 32 x 36 x 29,0	352,57	491,48		486,96
G	1.3/4-11h.	53,746	51,25	D 190 x 32 x 40 x 32,0	419,07			
G	2"-11h.	59,614	57,00	D 220 x 36 x 45 x 35,0	534,47			

* Disponibles también con rosca izquierda con 100% de recargo sobre los precios tarifados en rosca derecha

BSF

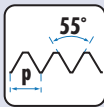

**HSS-Co
5%**

**TOL
ISO 228**

**Vc
12 m/min**

**D
MANGO
DELGADO**

**DIN
5156**

				M1D	M2D	M3D	M4D	
				FORMA C	FORMA B	15°	35°	
				€	€	€	€	
		D ₁ mm		L ₁ x L ₂ x D ₂ x ∅ mm				
	3/16-32h.	4,762	4,00	R 70 x 16 x 3,5 x 2,7	59,18			
	1/4-26h.	6,350	5,20	D 80 x 17 x 4,5 x 3,4	25,90			
	5/16-22h.	7,938	6,60	D 90 x 20 x 6,0 x 4,9	30,76			
	3/8-20h.	9,525	8,10	D 100 x 22 x 7,0 x 5,5	32,33			
	7/16-18h.	11,113	9,50	D 100 x 22 x 8,0 x 6,2	43,57			
	1/2-16h.	12,700	11,00	D 110 x 24 x 9,0 x 7,0	49,31			
	9/16-16h.	14,287	12,50	D 110 x 25 x 11,0 x 9,0	52,18			
	5/8-14h.	15,876	14,00	D 110 x 27 x 12,0 x 9,0	69,56			
	3/4-12h.	19,051	16,50	D 125 x 30 x 14,0 x 11,0	82,34			
	7/8-11h.	22,226	19,50	D 140 x 32 x 18,0 x 14,5	114,45			
	1"-10h.	25,400	22,50	D 160 x 36 x 18,0 x 14,5	133,03			

MACHOS PARA ROSCAR A MÁQUINA HSS-Co

UNC

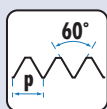

HSS-Co
5%

TOL
2B

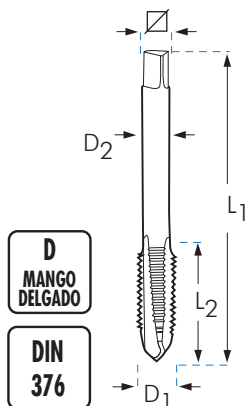

D
MANGO
DELGADO

DIN
376

Hasta
5/16-18h

R
MANGO
REFORZADO

DIN
371

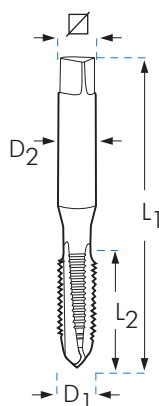

Vc
12 m/min



D1 mm	D2 mm	L1 x L2 x D2 x Ø	FORMA C	FORMA B	FORMA 15°	FORMA 35°
UNC n° 1-64h	1,85	1,50	R 40 x 8 x 2,5 x 2,1			
UNC n° 2-56h	2,18	1,80	R 45 x 9 x 2,8 x 2,1			
UNC n° 3-48h	2,51	2,10	R 50 x 9 x 2,8 x 2,1			
UNC n° 4-40h	2,84	2,25	R 56 x 11 x 3,5 x 2,7	17,95	21,54	24,58
UNC n° 5-40h	3,17	2,60	R 56 x 11 x 3,5 x 2,7	17,95	21,54	24,58
UNC n° 6-32h	3,50	2,75	R 56 x 12 x 4,0 x 3,0	17,08	20,52	23,40
UNC n° 8-32h	4,17	3,50	R 63 x 13 x 4,5 x 3,4	17,08	20,52	23,40
UNC n° 10-24h	4,83	3,90	R 70 x 15 x 6,0 x 4,9	17,95	21,54	24,58
UNC n° 12-24h	5,49	4,50	R 80 x 16 x 6,0 x 4,9	18,83	21,54	23,60
UNC 1/4-20h	6,35	5,10	R 80 x 17 x 7,0 x 5,5	16,78	18,30	21,11
UNC 5/16-18h	7,94	6,60	R 90 x 20 x 8,0 x 6,2	18,99	20,93	23,83

MANGO DELGADO PASOS NORMALES				M1D	M2D	M3D	M4D
UNC 3/8-16h	9,52	8,00	D 100 x 22 x 7,0 x 5,5	21,65	23,75		26,68
UNC 7/16-14h	11,11	9,40	D 100 x 22 x 8,0 x 6,2	29,79	29,90		37,39
UNC 1/2-13h	12,70	10,75	D 110 x 24 x 9,0 x 7,0	32,34	35,83		40,90
UNC 9/16-12h	14,28	12,20	D 110 x 26 x 11,0 x 9,0	44,45	48,80		55,52
UNC 5/8-11h	15,87	13,50	D 110 x 27 x 12,0 x 9,0	43,19	47,53		54,00
UNC 3/4-10h	19,05	16,50	D 125 x 30 x 14,0 x 11,0	57,18	62,85		71,51
UNC 7/8-9h	22,22	19,50	D 140 x 32 x 18,0 x 14,5	75,23	82,65		111,91
UNC 1"-8h	25,40	22,25	D 160 x 36 x 18,0 x 14,5	99,40	108,60		140,38
UNC 1.1/8-7h	28,57	25,00	D 180 x 40 x 22,0 x 18,0	129,84			164,05
UNC 1.1/4-7h	31,75	28,00	D 180 x 40 x 22,0 x 18,0	159,18			209,86
UNC 1.3/8-6h	34,92	30,75	D 200 x 50 x 28,0 x 22,0	237,43			
UNC 1.1/2-6h	38,10	34,00	D 200 x 50 x 32,0 x 24,0	269,63			
UNC 1.3/4-5h	44,45	39,00	D 220 x 58 x 36,0 x 29,0				
UNC 2"-4,5h	50,80	45,00	D 250 x 65 x 40,0 x 32,0				

MACHOS PARA ROSCAR A MÁQUINA HSS-Co

UNF

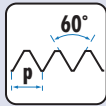

HSS-Co
5%

TOL
2B

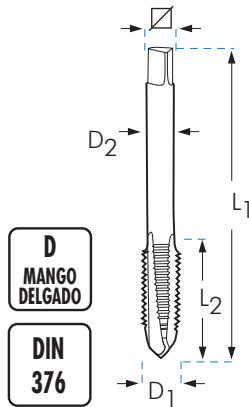

D
MANGO
DELGADO

DIN
376

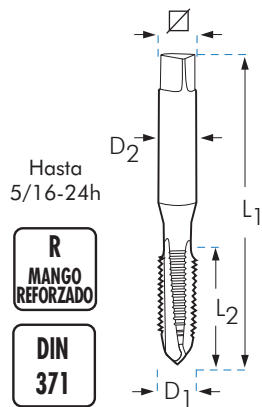

Hasta
5/16-24h

R
MANGO
REFORZADO

DIN
371

Vc
12 m/min



UNF nº	D1 mm	D2 mm	L1 x L2 x D2 x ∅	L1 x L2 x D2 x ∅ mm	M1R	M2R	M3R	M4R
					FORMA C €	FORMA B €	15° €	35° €
UNF nº 1-72h	1,85	1,50	R 40 x 8 x 2,5 x 2,1					
UNF nº 2-64h	2,18	1,85	R 45 x 9 x 2,8 x 2,1					
UNF nº 3-56h	2,51	2,15	R 50 x 9 x 2,8 x 2,1					
UNF nº 4-48h	2,84	2,35	R 56 x 11 x 3,5 x 2,7	19,69	21,44			26,91
UNF nº 5-44h	3,17	2,70	R 56 x 11 x 3,5 x 2,7	19,69	21,44			26,91
UNF nº 6-40h	3,50	2,95	R 56 x 12 x 4,0 x 3,0	18,83	22,55			26,70
UNF nº 8-36h	4,17	3,50	R 63 x 13 x 4,5 x 3,4	18,83	22,55			26,70
UNF nº10-32h	4,83	4,10	R 70 x 15 x 6,0 x 4,9	18,83	22,55			26,70
UNF nº12-28h	5,49	4,60	R 80 x 16 x 6,0 x 4,9	19,69	23,60			26,91
UNF 1/4-28h	6,35	5,50	R 80 x 17 x 7,0 x 5,5	15,91	17,53			19,88
UNF 5/16-24h	7,94	6,90	R 90 x 20 x 8,0 x 6,2	18,33	20,17			22,92

MANGO DELGADO PASOS NORMALES					M1D	M2D	M3D	M4D
UNF 3/8-24h	9,52	8,50	D 90 x 16 x 7,0 x 5,5		20,07	23,21		26,40
UNF 7/16-20h	11,11	9,90	D 100 x 22 x 8,0 x 6,2		25,70	29,79		33,84
UNF 1/2-20h	12,70	11,50	D 100 x 22 x 9,0 x 7,0		27,37	31,68		36,00
UNF 9/16-18h	14,29	12,90	D 100 x 22 x 11,0 x 9,0		33,63	38,94		44,58
UNF 5/8-18h	15,87	14,50	D 100 x 22 x 12,0 x 9,0		37,86	43,80		49,81
UNF 3/4-16h	19,05	17,50	D 110 x 25 x 14,0 x 11,0		48,44	56,10		63,72
UNF 7/8-14h	22,22	20,40	D 125 x 25 x 18,0 x 14,5		60,91	70,55		97,46
UNF 1"-12h	25,40	23,25	D 140 x 28 x 18,0 x 14,5		82,51	92,43		119,97
UNS 1"-14h	25,40	23,60	D 140 x 28 x 18,0 x 14,5		84,06	92,43		119,97
UNF 1.1/8-12h	28,57	26,50	D 150 x 28 x 22,0 x 18,0		125,72			
UNF 1.1/4-12h	31,75	29,50	D 150 x 28 x 22,0 x 18,0		158,88			
UNF 1.3/8-12h	34,92	33,00	D 170 x 30 x 28,0 x 22,0					
UNF 1.1/2-12h	38,10	36,00	D 170 x 30 x 32,0 x 24,0		266,65			
UNF 2"-12h	50,80	36,00						

MACHOS PARA ROSCAR A MÁQUINA HSS-Co

BSPP

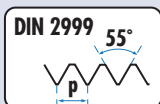

HSS-Co
5%

DIN
374

FORMA
C

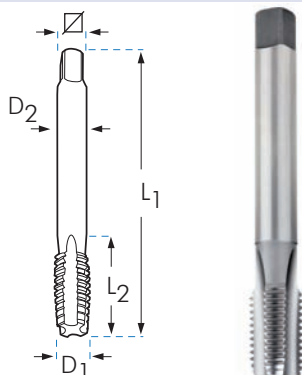

ROSCA CILÍNDRICA
INGLESA PARA TUBO

BSPT

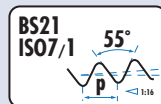

HSS-Co
5%

DIN
5156

FORMA
C

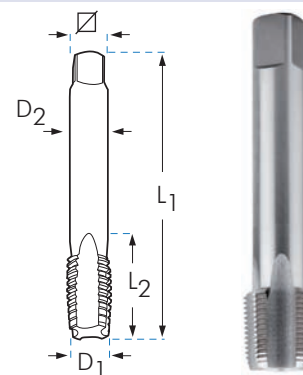

ROSCA CÓNICA
INGLESA PARA TUBO

	D ₁ mm	L ₁ x L ₂ x D ₂ x ∅	M1D €
Rp 1/16-28h.	7,72	D 90 x 16 x 6 x 4,9	
Rp 1/8-28h.	9,73	D 90 x 16 x 7 x 5,5	37,17
Rp 1/4-19h.	13,16	D 100 x 22 x 11 x 9,0	51,35
Rp 3/8-19h.	16,66	D 100 x 22 x 12 x 9,0	61,49
Rp 1/2-14h.	20,95	D 125 x 25 x 16 x 12,0	77,71
Rp 3/4-14h.	26,44	D 140 x 28 x 20 x 16,0	121,68
Rp 1"-11h.	33,25	D 160 x 30 x 25 x 20,0	188,79
Rp 1.1/4-11h.	41,91	D 170 x 30 x 32 x 24,0	
Rp 1.1/2-11h.	46,80	D 190 x 32 x 36 x 29,0	
Rp 2"-11h.	59,61	D 220 x 36 x 45 x 35,0	

	D ₁ mm	∅	L ₁ x L ₂ x D ₂ x ∅	M1D €
Rc 1/16-28h.	7,72		D 90x14x10,1x 6,0	
Rc 1/8-28h.	9,73	8,30	D 90x15x10,1x 7,0	39,50
Rc 1/4-19h.	13,16	11,00	D 100x19x15,0x11,0	56,80
Rc 3/8-19h.	16,66	14,50	D 100x21x15,4x12,0	78,94
Rc 1/2-14h.	20,95	18,10	D 125x26x20,5x16,0	109,69
Rc 5/8-14h.	22,91	21,00	D 140x36x18,0x14,5	170,39
Rc 3/4-14h.	26,44	23,50	D 140x28x21,8x20,0	171,08
Rc 7/8-14h.	30,20	28,25	D 160x36x22,0x18,0	297,71
Rc 1"-11h.	33,25	29,60	D 160x33x26,0x25,0	245,19

**NPS
(M)**

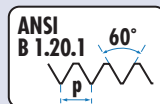

HSS-Co
5%

DIN
374

FORMA
C

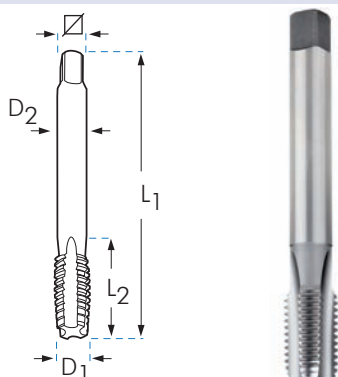

ROSCA CILÍNDRICA
AMERICANA PARA TUBO

NPT

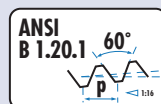

HSS-Co
5%

DIN
374

FORMA
C

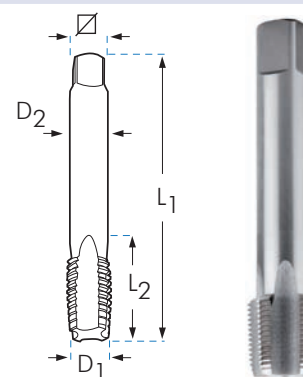

ROSCA CÓNICA
AMERICANA PARA TUBO

	D ₁ mm	∅	L ₁ x L ₂ x D ₂ x ∅	M1D €
NPS 1/8-27h.	10,08	9,1	D 90 x 16 x 7 x 5,5	99,44
NPS 1/4-18h.	13,36	12,0	D 100 x 22 x 11 x 9,0	142,31
NPS 3/8-18h.	16,81	15,5	D 100 x 22 x 12 x 9,0	195,16
NPS 1/2-14h.	20,90	19,0	D 125 x 25 x 16 x 12,0	267,61
NPS 3/4-14h.	26,26	24,5	D 140 x 28 x 20 x 16,0	395,61
NPS 1"-11,5 h.	32,84	30,5	D 160 x 30 x 25 x 20,0	511,59
NPS 1.1/4-11,5h.	41,60		D 170 x 30 x 32 x 24,0	
NPS 1.1/2-11,5h.	47,68		D 190 x 32 x 36 x 29,0	
NPS 2"-11,5h.	59,71		D 220 x 36 x 45 x 35,0	

	D ₁ mm	∅	L ₁ x L ₂ x D ₂ x ∅	M1D €
NPT 1/16-27h.	7,89	6,2	D 90x14x10,1x 6	32,10
NPT 1/8-27h.	10,24	8,5	D 90x15x10,1x 7	32,10
NPT 1/4-18h.	13,62	11,0	D 100x19x15,0x 11	45,01
NPT 3/8-18h.	17,05	14,5	D 100x21x15,4x 12	57,85
NPT 1/2-14h.	21,22	17,8	D 125x26x20,5x 16	75,26
NPT 3/4-14h.	26,57	23,0	D 140x28x21,8x 20	116,61
NPT 1"-11,5h.	33,23	29,0	D 160x33x26,0x 25	151,56
NPT 1.1/4-11,5h.	41,98	37,5	D 170x36x28,3x 32	199,35
NPT 1.1/2-11,5h.	48,05	44,0	D 190x37x28,3x 36	325,85
NPT 2"-11,5h.	60,09	56,0	D 220x41x32,7x 45	511,14

MACHOS DE ROSCAR A MÁQUINA HSS-Co

NPSF HSS-Co 5% DIN 374 FORMA C

60°

ROSCA PARA TUBO AMERICANA CILÍNDRICA

	D ₁ mm		L ₁ x L ₂ x D ₂ x ∅	M1D
				€
NPSF 1/8-27h.	10,05	8,75	D 90 x 16 x 7 x 5,5	119,94
NPSF 1/4-18h.	13,33	11,30	D 100 x 22 x 11 x 9,0	165,32
NPSF 3/8-18h.	16,78	14,70	D 100 x 22 x 12 x 9,0	235,18
NPSF 1/2-14h.	20,87	18,20	D 125 x 25 x 16 x 12,0	293,28
NPSF 3/4-14h.	26,23	23,50	D 140 x 28 x 20 x 16,0	480,00
NPSF 1"-11,5h.	32,81	29,50	D 160 x 30 x 25 x 20,0	

NPTF HSS-Co 5% DIN 374 FORMA C

60°

ROSCA PARA TUBO AMERICANA CÓNICA ESTANCA

	D ₁ mm		L ₁ x L ₂ x D ₂ x ∅	M1D
				€
NPTF 1/16-27h.	7,87	6,2	D 90 x 14 x 12,0 x 6	
NPTF 1/8-27h.	10,22	8,5	D 90 x 15 x 12,0 x 7	81,04
NPTF 1/4-18h.	13,58	11,0	D 100 x 21 x 17,5 x 11	113,68
NPTF 3/8-18h.	17,02	14,5	D 110 x 21 x 17,6 x 12	146,05
NPTF 1/2-14h.	21,21	17,8	D 140 x 27 x 22,8 x 16	190,13
NPTF 3/4-14h.	26,56	23,0	D 140 x 27 x 23,0 x 20	294,54

MF HSS-Co 5% TOL 6H DIN 374 FORMA C

60°

ROSCA MÉTRICA FINA PARA TUBO DE CONDUCCIÓN ELÉCTRICA EN 60423

	D ₁ mm		L ₁ x L ₂ x D ₂ x ∅	M1D
				€
MF 12 x 1,50	12	10,5	D 100 x 22 x 9 x 7,0	19,00
MF 16 x 1,50	16	14,5	D 100 x 22 x 12 x 9,0	26,77
MF 20 x 1,50	20	18,5	D 125 x 25 x 16 x 12,0	40,13
MF 25 x 1,50	25	23,5	D 140 x 28 x 18 x 14,5	92,43
MF 32 x 1,50	32	30,5	D 150 x 28 x 22 x 18,0	115,37
MF 40 x 1,50	40	38,5	D 170 x 30 x 32 x 24,0	201,39
MF 50 x 1,50	50	48,5	D 190 x 32 x 36 x 29,0	302,54
MF 63 x 1,50	63	61,5	D 275 x 36 x 50 x 39,0	

PG HSS-Co 5% DIN 40430 FORMA C

ANSI B 1.20.1 80°

ROSCA PARA TUBO DE CONDUCCIÓN ELÉCTRICA

	D ₁ mm		L ₁ x L ₂ x D ₂ x ∅	M1D
				€
PG 7 - 20h.	12,5	11,50	D 100 x 22 x 9 x 7,0	34,89
PG 9 - 18h.	15,2	14,00	D 100 x 22 x 12 x 9,0	48,30
PG 11 - 18h.	18,6	17,25	D 110 x 25 x 14 x 11,0	62,86
PG 13,5 - 18h.	20,4	19,00	D 125 x 25 x 16 x 12,0	70,58
PG 16 - 18h.	22,5	21,25	D 125 x 25 x 18 x 14,5	83,07
PG 21 - 16h.	28,3	27,00	D 150 x 28 x 22 x 18,0	131,88
PG 29 - 16h.	37,0	35,50	D 170 x 30 x 28 x 22,0	222,93
PG 36 - 16h.	47,0	45,50	D 190 x 32 x 36 x 29,0	362,06
PG 42 - 16h.	54,0	52,50	D 190 x 32 x 40 x 32,0	575,02
PG 48 - 16h.	59,3	58,00	D 220 x 36 x 45 x 35,0	700,99

MACHOS PARA ROSCAR A MÁQUINA HSS-Co

UNx8

HSS-Co
5%

DIN
374

FORMA
C

TOL
2B

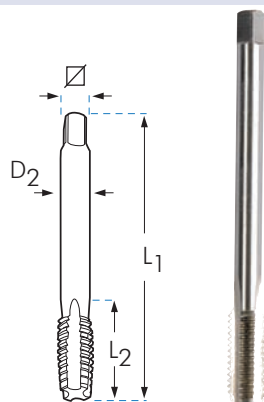
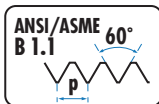

UNEF

HSS-Co
5%

DIN
374

TOL
2B

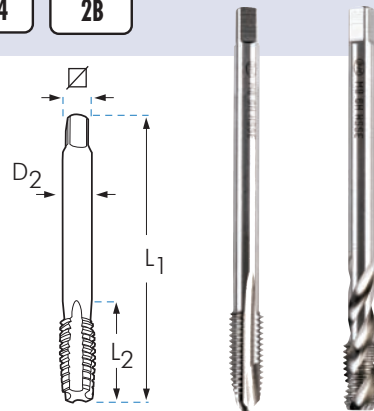
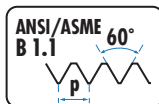

				M1D
		D ₂ mm	L ₁ x L ₂ x ∅ mm	€
UN 1" 1/8-8h.	25,40	22	180 x 45 x 18	229,08
UN 1" 1/4-8h.	28,50	22	180 x 48 x 18	295,54
UN 1" 3/8-8h.	31,75	28	200 x 56 x 22	335,26
UN 1" 1/2-8h.	35,00	32	200 x 58 x 22	400,17
UN 1" 5/8-8h.	38,10	32	200 x 65 x 24	468,10
UN 1" 3/4-8h.	41,25	36	200 x 50 x 29	570,23
UN 1" 7/8-8h.	44,45	36	225 x 53 x 29	638,03
UN 2"-8h.	47,63	40	225 x 50 x 32	672,08

					M2R	M4R
		D ₂ mm	L ₁ x L ₂ x ∅ mm	FORMA B	€	€
UNEF 1/4-32h.	5,55	7,0	R 82 x 16 x 5,4	35°	73,15	82,19
UNEF 5/16-32h.	7,15	8,4	R 85 x 21 x 6,1	35°	80,59	90,55
UNEF 3/8-32h.	8,70	7,0	D 95 x 22 x 5,4	35°	80,64	90,60
UNEF 7/16-28h.	10,20	8,0	D 100 x 22 x 6,2	35°	107,03	120,26
UNEF 1/2-28h.	11,80	9,0	D 100 x 22 x 7,0	35°	112,74	126,67
UNEF 9/16-24h.	13,20	12,0	D 100 x 24 x 9,0	35°	141,24	158,70
UNEF 5/8-24h.	14,80	12,0	D 100 x 24 x 9,0	35°	160,72	180,59
UNEF 3/4-20h.	17,80	14,0	D 110 x 27 x 11,0	35°	209,04	234,88
UNEF 7/8-20h.	20,95	18,0	D 125 x 26 x 14,5	35°	224,70	240,75
UNEF 1"-20h.	24,20	18,0	D 140 x 28 x 14,5	35°	343,86	386,36

MACHOS MÁQUINA MÉTRICA NORMA ISO 529

**M
MF**

HSS-Co
5%

ISO
529

TOL
6H

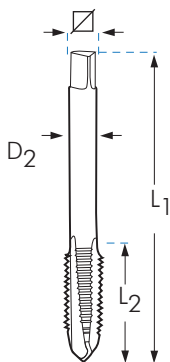
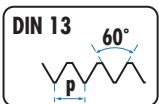

				M2RISO	M4RISO
			L ₁ x L ₂ x D ₂ x ∅ mm	FORMA B	35°
				€	€
M 3x0,50	2,50	R	48 x 11 x 3,15 x 2,50	6,19	7,45
M 4x0,70	3,30	R	53 x 13 x 4,00 x 3,15	6,19	7,45
M 5x0,80	4,20	R	58 x 16 x 5,00 x 4,00	6,19	7,45
M 6x1,00	5,00	R	66 x 19 x 6,30 x 5,00	6,19	7,62
M 8x1,25	6,75	R	72 x 22 x 8,00 x 6,30	8,26	8,55
M 10x1,50	8,50	R	80 x 24 x 10,00 x 8,00	10,51	11,02
MANGO DELGADO				M2DISO	M4DISO
M 12x1,75	10,20	D	89 x 29 x 9,00 x 7,10	13,51	14,31
M 14x2,00	12,00	D	95 x 30 x 11,20 x 9,00	16,15	19,56
M 16x2,00	14,00	D	102 x 32 12,50 x 10,00	20,07	22,69
M 18x2,50	15,50	D	112 x 37 x 14,00 x 11,20	30,21	37,76
M 20x2,50	17,50	D	112 x 37 x 14,00 x 11,20	33,76	42,20
M 22x2,50	19,50	D	118 x 38 x 16,00 x 12,50	39,04	48,80
M 24x3,00	21,00	D	130 x 45 x 18,00 x 14,00	44,10	55,13
M 27x3,00	24,00	D	135 x 45 x 20,00 x 16,00	54,31	67,89
M 30x3,50	26,50	D	138 x 48 x 20,00 x 16,00	80,69	100,86

MACHOS DE MÁQUINA Y COJINETES SERIE Plus

Plus

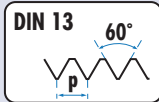

TOL 6H

PARA TRABAJOS DE ALTA PRODUCCIÓN
FABRICADOS EN ACERO SINTERIZADO

DIN 22568

TOL 6g

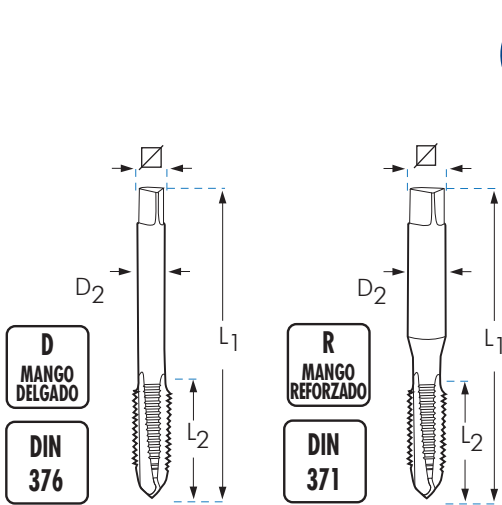

	M2RP	M4RP	M2RT	M4RT	M2RHL	M4RHL	C5P			
CALIDAD	★★	★★	★★★	★★★	★★★★	★★★★				
MATERIAL	HSS PM	HSS PM	HSS-Co 5%	HSS-Co 5%	HSS PM	HSS PM	HSS			
ACABADO	BRILLANTE	BRILLANTE	TiN	TiN	HARD LUBE	HARD LUBE	BRILLANTE			
ÁNGULO DE HÉLICE	FORMA B	35°	FORMA B	35°	FORMA B	35°				
	€	€	€	€	€	€	Ø x L3 mm €			
M 3x0,50	2,50	R 56 x 11 x 3,5 x 2,7	11,09*	13,71	16,09	17,78	21,95	24,01	25 x 9	21,99
M 4x0,70	3,30	R 63 x 13 x 4,5 x 3,4	11,33*	13,71	16,35	18,56	21,88	24,35	25 x 9	21,99
M 5x0,80	4,20	R 70 x 16 x 6,0 x 4,9	11,33*	13,14	16,35	18,44	21,39	24,35	25 x 9	21,99
M 6x1,00	5,00	R 80 x 17 x 6,0 x 4,9	12,46*	14,42	18,82	20,39	24,03	26,02	25 x 9	21,99
M 8x1,00	7,00	D 90 x 20 x 6,0 x 4,9	17,78	21,10	25,05	27,87	33,81	37,63	25 x 9	29,54
M 8x1,25	6,75	R 90 x 20 x 8,0 x 6,2	13,96*	16,46	22,01	23,93	28,35	31,13	25 x 9	22,98
M 10x1,00	9,00	D 90 x 16 x 7,0 x 5,5	19,83	24,87	29,25	33,59	39,48	46,65	38 x 10	36,10
M 10x1,50	8,50	R 100 x 22 x 10,0 x 8,0	17,16*	19,52	25,92	28,39	35,15	37,27	38 x 10	32,79

MANGO DELGADO		M2DP	M4DP	M2DT	M4DT	M2DHL	M4DHL			
M 12x1,50	10,50	D 100 x 22 x 9,0 x 7,0	23,53	28,44	32,29	36,36	45,86	52,60	38 x 10	40,84
M 12x1,75	10,20	D 110 x 24 x 9,0 x 7,0	22,12	26,27	31,39	35,39	42,74	49,80	38 x 14	36,06
M 14x1,50	12,50	D 100 x 22 x 11,0 x 9,0	27,87	34,95	37,98	43,56	53,94	61,85	38 x 10	42,70
M 14x2,00	12,00	D 110 x 26 x 11,0 x 9,0	27,66	32,07	38,74	42,58	54,51	59,91	38 x 14	36,76
M 16x1,50	14,50	D 100 x 22 x 12,0 x 9,0	34,86	42,99	45,64	52,20	50,41	62,17	45 x 14	58,65
M 16x2,00	14,00	D 110 x 27 x 12,0 x 9,0	32,53	38,75	44,23	48,89	62,23	68,78	45 x 18	49,38
M 18x2,50	15,50	D 125 x 30 x 14,0 x 11,0	46,11	52,09	56,03	61,13	81,04	88,41	45 x 18	49,38
M 20x2,50	17,50	D 140 x 32 x 16,0 x 12,0	49,82	55,53	63,87	68,81	92,37	99,53	45 x 18	49,38
M 22x2,50	19,50	D 140 x 32 x 18,0 x 14,5	60,27	68,52	74,90	83,25	108,33	118,22	55 x 22	74,10
M 24x3,00	21,00	D 160 x 34 x 18,0 x 14,5	71,66	82,03	84,40	95,23	122,07	135,22	55 x 22	74,10

* Disponibles también con rosca izquierda con 100% de recargo sobre los precios tarifados en rosca derecha

MACHOS DE MÁQUINA PARA TRABAJOS ESPECIALES HSS-PM

INOX

M

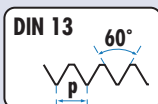

TOL
6H

D
MANGO
DELGADO
DIN
376

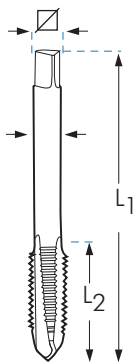

R
MANGO
REFORZADO
DIN
371

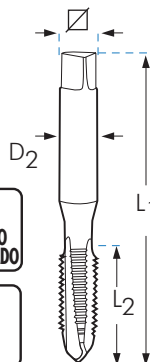

Vc
6 m/min



Vc
10 m/min



Vc
12 m/min



	M2RX	M4RX	M2RXT	M4RXT	M2RXHL	M4RXHL
CALIDAD	★★	★★	★★★	★★★	★★★★	★★★★
MATERIAL	HSS PM	HSS PM	HSS-Co 5%	HSS-Co 5%	HSS PM	HSS PM
ACABADO	OX	OX	TiN	TiN	HARD LUBE	HARD LUBE
ÁNGULO DE HÉLICE	FORMA B	35°	FORMA B	35°	FORMA B	35°
	L ₁ x L ₂ x D ₂ x □ mm		€	€	€	€

M 3x0,50	2,50	R 56 x 11 x 3,5 x 2,7	14,07	17,31	15,64	18,38	21,48	25,26
M 4x0,70	3,30	R 63 x 13 x 4,5 x 3,4	14,77	17,31	16,41	19,06	22,56	26,44
M 5x0,80	4,20	R 70 x 16 x 6,0 x 4,9	14,77	16,55	16,41	19,24	22,56	26,44
M 6x1,00	5,00	R 80 x 17 x 6,0 x 4,9	16,18	18,20	17,97	20,23	24,71	27,80
M 8x1,25	6,75	R 90 x 20 x 8,0 x 6,2	18,05	20,75	20,08	23,07	27,59	31,71
M 10x1,50	8,50	R 100 x 22 x 10,0 x 8,0	22,07	24,61	24,52	27,35	33,70	37,59

MANGO DELGADO		M2DX	M4DX	M2DXT	M4DXT	M2DXHL	M4DXHL	
M 12x1,75	10,20	D 110 x 24 x 9,0 x 7,0	28,36	33,20	31,50	35,12	42,53	49,80
M 14x2,00	12,00	D 110 x 26 x 11,0 x 9,0	40,37	44,32	41,85	44,15	56,52	62,59
M 16x2,00	14,00	D 110 x 27 x 12,0 x 9,0	44,95	51,16	44,40	53,39	62,93	75,70
M 18x2,50	15,50	D 125 x 30 x 14,0 x 11,0	67,33	72,78	71,24	75,99	100,98	107,70
M 20x2,50	17,50	D 140 x 32 x 16,0 x 12,0	72,76	76,85	75,72	80,22	107,35	113,72
M 22x2,50	19,50	D 140 x 32 x 18,0 x 14,5			102,94	108,20		
M 24x3,00	21,00	D 160 x 34 x 18,0 x 14,5			114,06	120,30		

INOX

BSP
(GAS)

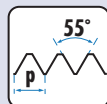

HSS
PM

OX

D
MANGO
DELGADO

DIN
515

MANGO DELGADO		M2DX	M4DX	
G 1/8x28	8,80	D 90 x 16 x 7 x 5,5	46,64	49,51
G 1/4x19	11,80	D 100 x 22 x 11 x 9,0	62,84	72,14
G 3/8x19	15,25	D 100 x 22 x 12 x 9,0	74,54	84,79
G 1/2x14	19,00	D 125 x 25 x 16 x 12,0	94,15	107,01
G 3/4x14	24,50	D 140 x 28 x 20 x 16,0	125,84	165,04

MACHOS DE MÁQUINA PARA TRABAJOS ESPECIALES HSS-V3

1200
N/mm²

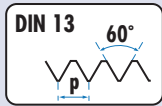

HSS V3

TOL 6H

MATERIALES DUROS

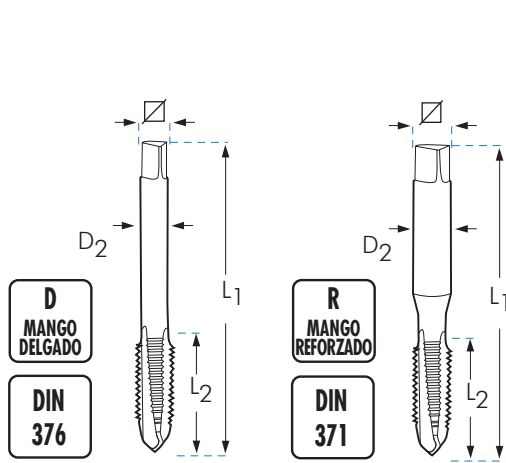

Vc 7 m/min

Vc 9 m/min



				M2RMD	M4RMD	M2RMDTX	M4RMDTX
CALIDAD				★★★	★★★	★★★★	★★★★
MATERIAL				HSS V3	HSS V3	HSS V3	HSS V3
ACABADO				OX	OX	TINALOX	TINALOX
ÁNGULO DE HÉLICE				FORMA B	35°	FORMA B	35°
				€	€	€	€
M 3x0,50	2,50	R 56 x 11 x 3,5 x 2,7		12,67	14,99	18,07	21,24
M 4x0,70	3,30	R 63 x 13 x 4,5 x 3,4		13,29	14,99	18,98	22,24
M 5x0,80	4,20	R 70 x 16 x 6,0 x 4,9		13,29	14,75	18,98	22,24
M 6x1,00	5,00	R 80 x 17 x 6,0 x 4,9		14,57	16,23	20,79	23,38
M 8x1,25	6,75	R 90 x 20 x 8,0 x 6,2		16,26	17,97	23,20	26,67
M 10x1,50	8,50	R 100 x 22 x 10,0 x 8,0		19,11	21,31	29,36	32,75
MANGO DELGADO				M2DMD	M4DMD	M2DMDTX	M4DMDTX
M 12x1,75	10,20	D 110 x 24 x 9,0 x 7,0		25,78	28,74	37,74	44,17
M 14x2,00	12,00	D 110 x 26 x 11,0 x 9,0		32,68	38,36	53,71	58,96
M 16x2,00	14,00	D 110 x 27 x 12,0 x 9,0		38,20	46,40	59,83	71,31
M 18x2,50	15,50	D 125 x 30 x 14,0 x 11,0		54,51	66,02	87,94	99,60
M 20x2,50	17,50	D 140 x 32 x 16,0 x 12,0		58,92	69,70	95,05	105,14

MACHOS DE MÁQUINA PARA TRABAJOS ESPECIALES TICN

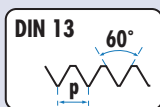

MATERIALES MUY DUROS

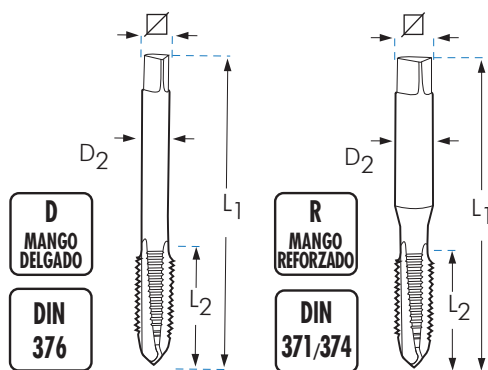

Vc
5 m/min



				M2RC	M3RC
				FORMA B	15°
				€	€
		L ₁ x L ₂ x D ₂ x ∅ mm			
M 3 x 0,50	2,50	R 56 x 11 x 3,5 x 2,7		22,02	23,65
M 4 x 0,70	3,30	R 63 x 13 x 4,5 x 3,4		23,09	25,18
M 5 x 0,80	4,20	R 70 x 16 x 6,0 x 4,9		22,87	24,61
M 6 x 1,00	5,00	R 80 x 17 x 6,0 x 4,9		24,79	28,59
M 8 x 1,00	7,00	D 90 x 20 x 6,0 x 4,9		33,25	37,66
M 8 x 1,25	6,75	R 90 x 20 x 8,0 x 6,2		28,63	32,04
M10 x 1,00	9,00	D 90 x 16 x 7,0 x 5,5		39,59	44,21
M10 x 1,50	8,50	R 100 x 22 x 10,0 x 8,0		34,28	39,70

				M2DC	M3DC
M12 x 1,50	10,50	D 100 x 22 x 9,0 x 7,0		43,62	48,98
M12 x 1,75	10,20	D 110 x 24 x 9,0 x 7,0		41,89	54,18
M14 x 1,50	12,50	D 100 x 22 x 11,0 x 9,0		49,87	56,81
M14 x 2,00	12,00	D 110 x 26 x 11,0 x 9,0		49,91	55,13
M16 x 2,00	14,00	D 110 x 27 x 12,0 x 9,0		56,31	63,33
M18 x 2,50	15,50	D 125 x 30 x 14,0 x 11,0		71,30	78,46
M20 x 2,50	17,50	D 140 x 32 x 16,0 x 12,0		83,47	90,83

MACHOS DE MÁQUINA PARA MATERIALES EXTREMADAMENTE DUROS FABRICADOS EN METAL DURO + TICN

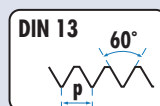

MATERIALES 48-62 Hrc



- Lubricación: **Tap Magic** XTRA-THICK
- Se recomienda roscar la pieza sobre el mismo utillaje utilizado para el taladro previo y en la misma posición, para garantizar coaxialidad entre macho y orificio previo.

Hrc	Vc (m/min)
48 Hrc	8 m/min
56 Hrc	6 m/min
62 Hrc	3 m/min

				M1RHMC	
				FORMA C	€
		L ₁ x L ₂ x D ₂ x ∅ mm			
M 5 x 0,80	4,30	R 70 x 16 x 6,0 x 4,9		221,43	
M 6 x 1,00	5,10	R 80 x 17 x 6,0 x 4,9		221,43	
M 8 x 1,25	6,90	R 90 x 20 x 8,0 x 6,2		249,22	
M10 x 1,50	8,60	R 100 x 22 x 10,0 x 8,0		318,67	

				M1DHMC	
M12 x 1,75	10,40	D 110 x 24 x 9,0 x 7,0		352,29	

MACHOS DE MÁQUINA TODO TERRENO

TODO TERRENO

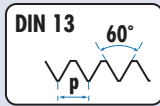

HSS-Co
5%

TiN

TOL
6H

APLICACIONES

Al

1200
N/mm²

FUNDICIÓN

Ti

INOX

Vc
13 m/min

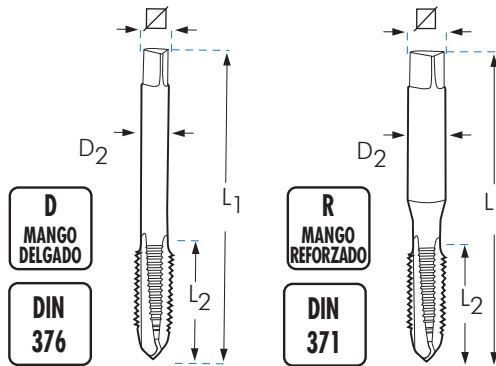

 $L_1 \times L_2 \times D_2 \times \square$ mm	M2RD		M4RD		
	FORMA B	€	35°	€	
M 3 x 0,50	2,50	R 56 x 11 x 3,5 x 2,7	20,33	23,74	
M 4 x 0,70	3,30	R 63 x 13 x 4,5 x 3,4	20,33	23,74	
M 5 x 0,80	4,20	R 70 x 16 x 6,0 x 4,9	21,63	24,60	
M 6 x 1,00	5,00	R 80 x 17 x 6,0 x 4,9	22,38	25,53	
M 8 x 1,25	6,75	R 90 x 20 x 8,0 x 6,2	26,22	29,14	
M10 x 1,50	8,50	R 100 x 22 x 10,0 x 8,0	30,26	34,51	
MANGO DELGADO		M2DD		M4DD	
M12 x 1,75	10,20	D 110 x 24 x 9,0 x 7,0	38,12	45,38	
M14 x 2,00	12,00	D 110 x 26 x 11,0 x 9,0	49,79	54,71	
M16 x 2,00	14,00	D 110 x 27 x 12,0 x 9,0	55,79	60,38	
M18 x 2,50	15,50	D 125 x 30 x 14,0 x 11,0	87,18	89,40	
M20 x 2,50	17,50	D 140 x 32 x 16,0 x 12,0	88,80	92,13	

MACHOS DE MÁQUINA PARA TRABAJOS ESPECIALES HSS-Co

AI
FUNDICIÓN
LATÓN
DIN 13 60°
HSS-Co 5%
TOL 6H

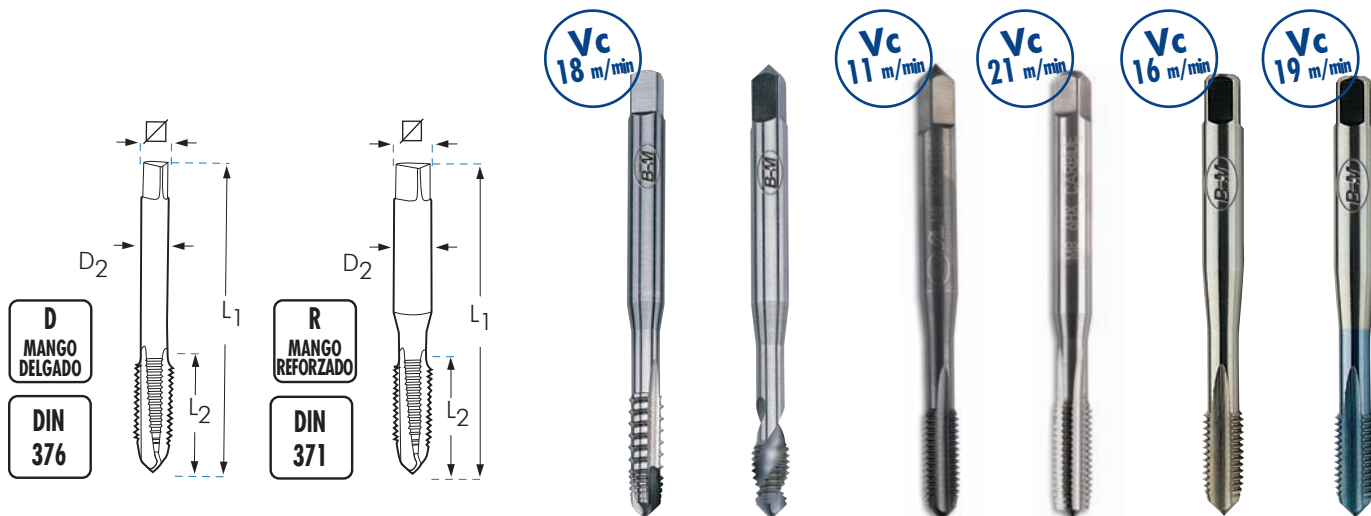

	M5R	M6R	M1RFM	MHM1R	M1RL	M1RLCRN
APLICACIÓN	AI	AI	FUNDICIÓN	FUNDICIÓN	LATÓN	LATÓN
MATERIAL	HSS-Co 5%	HSS-Co 5%	HSS-Co 5%	MD	HSS-Co 5%	HSS-Co 5%
ACABADO	BRILLANTE	BRILLANTE	OX	BRILLANTE	BRILLANTE	CrN
FORMA	DIENTE ALTERNO	2 CANALES	FORMA C	FORMA C	FORMA C	FORMA C
$L_1 \times L_2 \times D_2 \times \square$ mm	€	€	€	€	€	€

M 3 x 0,50	2,50	R 56 x 11 x 3,5 x 2,7	16,87	16,64	11,93	54,19	14,42	16,38
M 4 x 0,70	3,30	R 63 x 13 x 4,5 x 3,4	16,95	16,64	12,34	54,19	15,31	18,05
M 5 x 0,80	4,20	R 70 x 16 x 6,0 x 4,9	16,87	16,98	12,34	54,19	15,31	18,12
M 6 x 1,00	5,00	R 80 x 17 x 6,0 x 4,9	17,77	18,36	14,01	61,80	16,78	19,79
M 8 x 1,25	6,75	R 90 x 20 x 8,0 x 6,2	21,27	22,01	15,69	69,01	19,13	24,07
M10 x 1,50	8,50	R 100 x 22 x 10,0 x 8,0	27,19	26,03	17,94	86,48	23,01	29,28

MANGO DELGADO		M5D	M6D	M1DFM	MHM1D	M1DL	M1DLCRN	
M12 x 1,75	10,20	D 110 x 24 x 9,0 x 7,0	33,92	33,03	22,57	120,67	26,85	35,38
M14 x 2,00	12,00	D 110 x 26 x 11,0 x 9,0	61,43	41,82	37,09	188,00	32,96	43,12
M16 x 2,00	14,00	D 110 x 27 x 12,0 x 9,0	66,95	54,73	43,65	223,66	37,92	48,21
M18 x 2,50	15,50	D 125 x 30 x 14,0 x 11,0			61,06	274,16	49,74	61,06
M20 x 2,50	17,50	D 140 x 32 x 16,0 x 12,0			61,29	331,99	55,83	67,98

MACHOS DE MÁQUINA PARA ROSCADO POR LAMINACIÓN

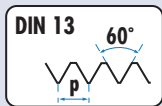

HSS-Co
5%

TOL
6HX

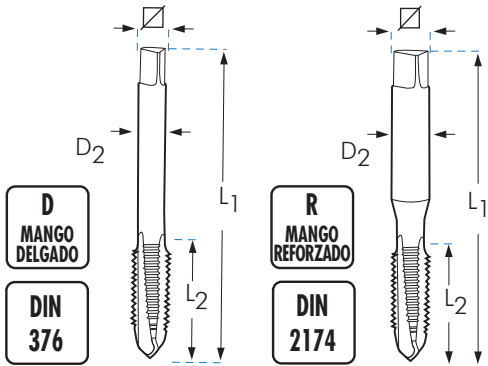

		M07R	M07RT	M07RCR	M07RTCR	M07RCCR		
APLICACIÓN								
MATERIAL		HSS-Co 5%	HSS-Co 5%	HSS-Co 5%	HSS-Co 5%	HSS-Co 5%		
ACABADO		OX	TiN	OX	TiN	TiCN		
FORMA								
	$L_1 \times L_2 \times D_2 \times \square$ mm	€	€	€	€	€		
M	3x0,50	2,75	R 56 x 11 x 3,5 x 2,7	22,36	25,44	24,15	28,49	33,10
M	3,5x0,60	3,20	R 56 x 11 x 3,5 x 2,7	23,50	27,02	24,96	30,89	35,03
M	4x0,70	3,65	R 63 x 13 x 4,5 x 3,4	22,36	26,54	24,15	29,72	34,52
M	5x0,80	4,60	R 70 x 16 x 6,0 x 4,9	22,36	26,54	24,15	29,72	34,52
M	6x1,00	5,50	R 80 x 17 x 6,0 x 4,9	24,14	28,05	26,06	31,42	36,48
M	8x1,25	7,40	R 90 x 20 x 8,0 x 6,2	28,13	37,02	30,39	41,46	48,16
M	10x1,50	9,30	R 100 x 22 x 10,0 x 8,0	31,29	41,50	33,80	45,64	53,01
MANGO DELGADO		M07D	M07DT	M07DCR	M07DTCR	M07DCCR		
M	12x1,75	11,20	D 110 x 24 x 9,0 x 7,0	36,87	52,27	39,82	58,54	60,70
M	14x2,00	13,05	D 110 x 26 x 11,0 x 9,0	66,48	85,71	70,40	93,86	89,38
M	16x2,00	15,05	D 110 x 27 x 12,0 x 9,0	78,05	96,54	82,64	105,73	90,83
M	18x2,50	16,80	D 125 x 30 x 14,0 x 11,0	89,56	111,16	94,83	117,39	111,80
M	20x2,50	18,80	D 140 x 32 x 16,0 x 12,0	118,00	168,28	124,96	177,70	156,89

BROCA MACHO HSS-Co

Machos y Terrajas

Rosa

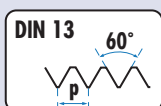

HSS-Co
5%

BRILLANTE

TOL
6H

R
MANGO
REFORZADO

DIN
371

D
MANGO
DELGADO

DIN
376

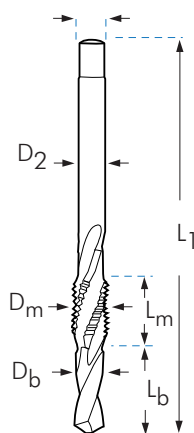

								M8M
								FORMA A
								€
		L _b mm	L _m mm	L ₁ mm	D _b mm	D _m mm	D ₂ mm	∅ mm
M 3x0,50	R	9,0 x 12,5 x	62,0 x	2,50 x	3,0 x	3,5 x	2,7	26,37
M 4x0,70	R	10,0 x 16,0 x	66,0 x	3,30 x	4,0 x	4,5 x	3,4	26,37
M 5x0,80	R	12,5 x 18,0 x	75,5 x	4,20 x	5,0 x	6,0 x	4,9	27,41
M 6x1,00	R	14,0 x 20,0 x	81,0 x	5,00 x	6,0 x	6,0 x	4,9	30,27
M 8x1,00	R	20,0 x 14,0 x	91,0 x	7,00 x	8,0 x	6,0 x	4,9	34,23
M 8x1,25	R	20,0 x 14,0 x	91,0 x	6,75 x	8,0 x	8,0 x	6,2	36,86

MANGO DELGADO									
M	D	L _b	L _m	L ₁	D _b	D _m	D ₂	∅	€
M 8x1,25	D	20,0 x 14,0 x	91,0 x	6,75 x	8,0 x	6,0 x	4,9	36,86	
M 10x1,00	D	20,0 x 15,0 x	95,0 x	9,00 x	10,0 x	7,0 x	5,5	42,50	
M 10x1,50	D	25,0 x 18,0 x	105,0 x	8,50 x	10,0 x	7,0 x	5,5	46,80	
M 12x1,50	D	24,0 x 18,0 x	110,0 x	10,50 x	12,0 x	9,0 x	7,0	49,23	
M 12x1,75	D	28,0 x 20,0 x	118,0 x	10,20 x	12,0 x	9,0 x	7,0	50,79	
M 14x1,50	D	28,0 x 20,0 x	118,0 x	12,50 x	14,0 x	11,0 x	9,0	77,91	
M 14x2,00	D	28,0 x 22,0 x	130,0 x	12,00 x	14,0 x	11,0 x	9,0	88,62	
M 18x2,50	D	40,0 x 26,0 x	151,0 x	15,50 x	18,0 x	14,0 x	11,0	169,98	
M 20x2,50	D	45,0 x 30,0 x	168,0 x	17,50 x	20,0 x	16,0 x	12,0	244,10	

MACHOS DE MÁQUINA ROSCA TRAPEZOIDAL HSS

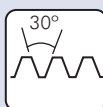

HSS

BRILLANTE



DIN
103

TOL
7H

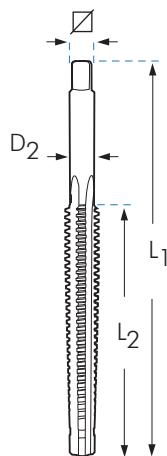

				MRTM
				€
			L ₁ x L ₂ x D ₂ x ∅ mm	
Tr 14 x 3	11,25	160 x 105 x	10,5 x 8,0	430,51
Tr 16 x 4	12,25	205 x 110 x	11,5 x 9,0	448,18
Tr 18 x 4	14,25	215 x 120 x	13,0 x 10,0	472,46
Tr 20 x 4	16,25	230 x 130 x	15,0 x 12,0	474,67
Tr 22 x 5	17,25	270 x 165 x	16,0 x 12,0	624,80
Tr 24 x 5	19,25	280 x 165 x	18,0 x 14,5	708,70
Tr 26 x 5	21,25	290 x 170 x	20,0 x 16,0	733,28
Tr 28 x 5	23,25	300 x 180 x	22,0 x 18,0	830,65
Tr 30 x 6	24,25	345 x 200 x	23,0 x 18,0	955,96

MACHOS DE MÁQUINA EXTRALARGOS HSS-Co

FORMA B



HSS-Co 5%

BRILLANTE

TOL 6H

R MANGO REFORZADO

DIN 371

D MANGO DELGADO

DIN 376

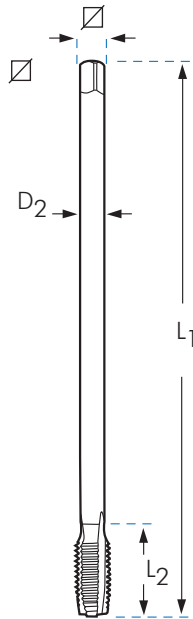

				M2L	
				FORMA B	
				€	
			$L_1 \times L_2 \times D_2 \times \square$ mm		
M	3x0,50	2,50	R 100 x 10 x 4,0 x 3,2	28,08	
M	4x0,70	3,30	R 120 x 12 x 5,0 x 4,0	28,70	
M	5x0,80	4,20	R 140 x 14 x 5,5 x 4,5	28,70	
M	6x1,00	5,00	R 160 x 16 x 6,0 x 4,5	31,54	
M	8x1,25	6,75	R 180 x 18 x 8,0 x 6,2	36,98	

		MANGO DELGADO		M2L-D	
M	6x1,00	5,00	D 160 x 16 x 4,5 x 3,4	32,13	
M	8x1,25	6,75	D 180 x 18 x 6,2 x 5,0	37,68	
M	10x1,50	8,50	D 200 x 20 x 7,0 x 5,5	45,52	
M	12x1,75	10,20	D 220 x 22 x 8,5 x 6,5	56,01	
M	14x2,00	12,00	D 220 x 25 x 10,5 x 8,0	85,26	
M	16x2,00	14,00	D 220 x 28 x 12,5 x 10,0	100,29	
M	18x2,50	15,50	D 250 x 32 x 14,0 x 11,0	182,49	
M	20x2,50	17,50	D 250 x 32 x 16,0 x 12,0	197,24	

35°



HSS-Co 5%

BRILLANTE

TOL 6H

R MANGO REFORZADO

DIN 371

D MANGO DELGADO

DIN 376

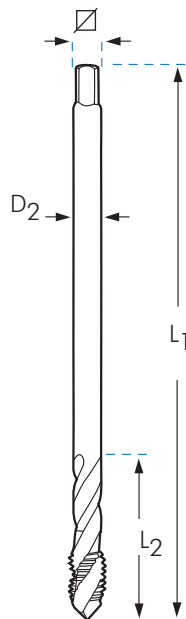

				M4L	
				35°	
				€	
			$L_1 \times L_2 \times D_2 \times \square$ mm		
M	3x0,50	2,50	R 100 x 10 x 4,0 x 3,2	34,75	
M	4x0,70	3,30	R 120 x 12 x 5,0 x 4,0	34,75	
M	5x0,80	4,20	R 140 x 14 x 5,5 x 4,5	33,29	
M	6x1,00	5,00	R 160 x 16 x 6,0 x 4,5	36,52	
M	8x1,25	6,75	R 180 x 18 x 8,0 x 6,2	44,37	

		MANGO DELGADO		M4L-D	
M	6x1,00	5,00	D 160 x 16 x 4,5 x 3,4	37,21	
M	8x1,25	6,75	D 180 x 18 x 6,2 x 5,0	43,54	
M	10x1,50	8,50	D 200 x 20 x 7,0 x 5,5	51,43	
M	12x1,75	10,20	D 220 x 22 x 8,5 x 6,5	66,52	
M	14x2,00	12,00	D 220 x 25 x 10,5 x 8,0	95,53	
M	16x2,00	14,00	D 220 x 28 x 12,5 x 10,0	138,46	
M	18x2,50	15,50	D 250 x 32 x 14,0 x 11,0	206,64	
M	20x2,50	17,50	D 250 x 32 x 16,0 x 12,0	219,91	

MACHOS TUERQUEROS DE ROSCA MÉTRICA DIN 357



HSS-Co
5%

BRILLANTE

TOL
6H

DIN
357

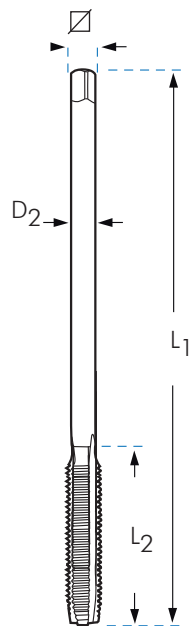

			MTU	
			FORMA	C
			€	
			L ₁ x L ₂ x D ₂ x ∅ mm	
M 3x0,50*	2,50	D 70 x 22 x 2,2	19,00	
M 4x0,70	3,30	D 90 x 25 x 2,8 x 2,1	19,00	
M 5x0,80	4,20	D 100 x 28 x 3,5 x 2,7	19,00	
M 6x1,00	5,00	D 110 x 32 x 4,5 x 3,4	19,00	
M 8x1,25	6,80	D 125 x 40 x 6,0 x 4,9	22,20	
M 10x1,50	8,50	D 140 x 45 x 7,0 x 5,5	25,56	
M 12x1,75	10,20	D 180 x 50 x 9,0 x 7,0	41,98	
M 14x2,00	12,00	D 200 x 56 x 11,0 x 9,0	48,91	
M 16x2,00	14,00	D 200 x 63 x 12,0 x 9,0	60,56	
M 18x2,50	15,50	D 220 x 63 x 14,0 x 11,0	81,47	
M 20x2,50	17,50	D 250 x 70 x 16,0 x 12,0	99,31	
M 22x2,50	19,50	D 280 x 80 x 18,0 x 14,5	123,02	
M 24x3,00	21,00	D 280 x 80 x 18,0 x 14,5	167,38	

* Mango cilíndrico

powercoil
by CELESA

INSERTOS PARA LA REPARACIÓN
Y FORTALECIMIENTO DE ROSCAS

Repare
roscas en
4 pasos

LA SOLUCIÓN AL ROSCADO DE PRECISIÓN

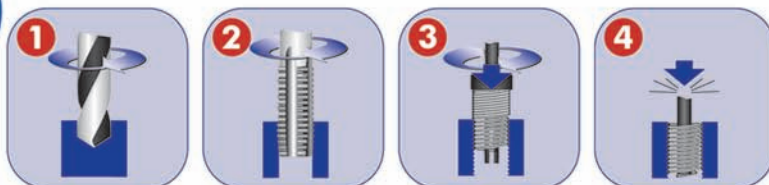

MACHOS DE MÁQUINA HSS-Co TOLERANCIAS ESPECIALES Y SOBREMEDIDAS



	M2R4H		M4R4H		M2R6G		M4R6G		M2R7G		M4R7G		M2R+0,1		M4R+0,1		M2R+0,2		M4R+0,2			
TOLERANCIA	TOL 4H		TOL 4H		TOL 6G		TOL 6G		TOL 7G		TOL 7G		TOL 6H (+0,1)		TOL 6H (+0,1)		TOL 6H (+0,2)		TOL 6H (+0,2)			
MATERIAL	HSS-Co 5%		HSS-Co 5%		HSS-Co 5%		HSS-Co 5%		HSS-Co 5%		HSS-Co 5%		HSS-Co 5%		HSS-Co 5%		HSS-Co 5%		HSS-Co 5%			
ACABADO	BRILLANTE		BRILLANTE		BRILLANTE		BRILLANTE		BRILLANTE		BRILLANTE		BRILLANTE		BRILLANTE		BRILLANTE		BRILLANTE			
FORMA	FORMA B		FORMA B 35°		FORMA B		FORMA B 35°		FORMA B		FORMA B 35°		FORMA B		FORMA B 35°		FORMA B		FORMA B 35°			
	L ₁ x L ₂ x D ₂ x ∅		L ₁ x L ₂ x D ₂ x ∅		L ₁ x L ₂ x D ₂ x ∅		L ₁ x L ₂ x D ₂ x ∅		L ₁ x L ₂ x D ₂ x ∅		L ₁ x L ₂ x D ₂ x ∅		L ₁ x L ₂ x D ₂ x ∅		L ₁ x L ₂ x D ₂ x ∅		L ₁ x L ₂ x D ₂ x ∅		L ₁ x L ₂ x D ₂ x ∅			
	€		€		€		€		€		€		€		€		€		€			
M 3x0,50	2,75	R 56x11x 3,5x 2,7	17,27	21,36	14,39	17,12	17,27	21,36	17,83	22,90	19,70	24,39										
M 4x0,70	3,65	R 63x13x 4,5x 3,4	17,67	21,36	14,39	17,12	17,67	21,36	18,25	22,90	20,16	24,39										
M 5x0,80	4,60	R 70x16x 6,0x 4,9	17,67	20,47	14,39	16,80	17,67	20,47	18,25	21,94	20,16	23,36										
M 6x1,00	5,50	R 80x17x 6,0x 4,9	19,43	22,46	15,49	18,45	19,43	22,46	20,04	24,07	22,15	25,63										
M 8x1,00	7,00	D 90x20x 6,0x 4,9			30,17	33,37																
M 8x1,25	7,40	R 90x20x 8,0x 6,2	21,75	25,64	18,01	21,62	21,75	25,64	22,46	27,48	24,82	29,26										
M 10x1,00	9,00	D 90x16x 7,0x 5,5			35,63	41,47																
M 10x1,50	9,30	R 100x22x10,0x 8,0	26,74	30,43	22,16	24,74	26,74	30,43	27,62	32,58	30,53	34,69										
MANGO DELGADO			M2D4H		M4D4H		M2D6G		M4D6G		M2D7G		M4D7G		M2D+0,1		M4D+0,1		M2D+0,2		M4D+0,2	
M 12x1,50	10,50	D 100x22x 9,0x 7,0					63,03	74,73														
M 12x1,75	11,20	D 110x24x 9,0x 7,0	34,49	40,94	28,38	34,18	34,49	40,94	34,59	43,85	39,31	46,70										
M 14x2,00	13,05	D 110x26x11,0x 9,0			34,86	41,88			56,43	69,82	64,14	74,35										
M 16x2,00	15,05	D 110x27x12,0x 9,0			43,09	50,58			66,38	84,37	75,45	89,84										
M 18x2,50	16,80	D 125x30x14,0x11,0			60,76	62,63			100,36	113,63	106,87	121,00										
M 20x2,50	18,80	D 140x32x16,0x12,0			62,75	71,98			108,45	120,91	115,48	128,76										

4H.- Para roscas muy precisas. Ajuste más exacto.

6G.- Para roscas con recubrimientos. Espesores entre 20 - 40 μ

7G.- Para roscas con recubrimientos. Espesores entre 40 - 50 μ

6H. (+0,1)- Para obtener roscas con sobremedidas o para compensar deformaciones de tratamientos térmicos.

6H. (+0,2)- Para obtener roscas con sobremedidas o para compensar deformaciones de tratamientos térmicos.

MACHOS DE MÁQUINA HSS-Co EN ESTUCHES METÁLICOS

USO GENERAL

**HSS-Co
5%**



Ref. **JM6**



Ref. **JM2**



Ref. **JM8**



Ref. **JM4**

CONTENIDO

P.V.P. €

FORMA C

FORMA B



HSS

**HSS-Co
5%**

	FORMA C	FORMA B	15°	35°	HSS	HSS-Co 5%	P.V.P. €
JM5	M3 - M4 - M5 - M6 M8 - M10 - M12	-	-	-	-	-	97,02
JM1	M3 - M4 - M5 - M6 M8 - M10 - M12	-	-	-	2.5 / 3.3 / 4.2 / 5.0 6.8 / 8.5 / 10.2 mm	-	116,04
JM6	-	M3 - M4 - M5 - M6 M8 - M10 - M12	-	-	-	-	103,37
JM2	-	M3 - M4 - M5 - M6 M8 - M10 - M12	-	-	2.5 / 3.3 / 4.2 / 5.0 6.8 / 8.5 / 10.2 mm	-	116,25
JM7	-	-	M3 - M4 - M5 - M6 M8 - M10 - M12	-	-	-	118,78
JM3	-	-	M3 - M4 - M5 - M6 M8 - M10 - M12	-	2.5 / 3.3 / 4.2 / 5.0 6.8 / 8.5 / 10.2 mm	-	141,92
JM8	-	-	-	M3 - M4 - M5 - M6 M8 - M10 - M12	-	-	120,83
JM4	-	-	-	M3 - M4 - M5 - M6 M8 - M10 - M12	2.5 / 3.3 / 4.2 / 5.0 6.8 / 8.5 / 10.2 mm	-	140,41

MACHOS DE MÁQUINA EN ESTUCHES METÁLICOS

Plus



Ref. **JMPT2**

CONTENIDO						P.V.P. €	
FORMA B	BRILLANTE	35°	BRILLANTE	HSS-Co 5%	HSS PM	TiN	
JMP6	M3 - M4 - M5 - M6 M8 - M10 - M12	-	-	-	99,35	JMPT6	143,29
JMP2	M3 - M4 - M5 - M6 M8 - M10 - M12	-	-	2.5 / 3.3 / 4.2 / 5.0 6.8 / 8.5 / 10.2 mm	134,19	JMPT2	174,35
JMP8	-	M3 - M4 - M5 - M6 M8 - M10 - M12	-	-	143,29	JMPT8	157,82
JMP4	-	M3 - M4 - M5 - M6 M8 - M10 - M12	-	2.5 / 3.3 / 4.2 / 5.0 6.8 / 8.5 / 10.2 mm	174,35	JMPT4	188,97

INOX

CONTENIDO						P.V.P. €	
FORMA B	OX	35°	OX	HSS-Co 5%	HSS PM	TiN	
JMX6	M3 - M4 - M5 - M6 M8 - M10 - M12	-	-	-	128,17	JMXT6	139,82
JMX2	M3 - M4 - M5 - M6 M8 - M10 - M12	-	-	2.5 / 3.3 / 4.2 / 5.0 6.8 / 8.5 / 10.2 mm	159,23	JMXT2	170,88
JMX8	-	M3 - M4 - M5 - M6 M8 - M10 - M12	-	-	146,27	JMXT8	161,25
JMX4	-	M3 - M4 - M5 - M6 M8 - M10 - M12	-	2.5 / 3.3 / 4.2 / 5.0 6.8 / 8.5 / 10.2 mm	177,32	JMXT4	192,30

1200
N/mm²

CONTENIDO						P.V.P. €	
FORMA B	OX	35°	OX	HSS-Co 5%	HSS V3	TINALOX	
JMMD6	M3 - M4 - M5 - M6 M8 - M10 - M12	-	-	-	116,50	JMMDT6	165,41
JMMD2	M3 - M4 - M5 - M6 M8 - M10 - M12	-	-	2.5 / 3.3 / 4.2 / 5.0 6.8 / 8.5 / 10.2 mm	147,56	JMMDT2	196,46
JMMD8	-	M3 - M4 - M5 - M6 M8 - M10 - M12	-	-	132,96	JMMDT8	190,73
JMMD4	-	M3 - M4 - M5 - M6 M8 - M10 - M12	-	2.5 / 3.3 / 4.2 / 5.0 6.8 / 8.5 / 10.2 mm	164,02	JMMDT4	221,78

MACHOS DE MÁQUINA EN ESTUCHES METÁLICOS

1400
N/mm²



Ref. **JMC2**

CONTENIDO

P.V.P. €

FORMA
B

TiCN



15°

TiCN



HSS-Co
5%

ASP
23

JMC6	M3 - M4 - M5 - M6 M8 - M10 - M12	-	-	198,19
JMC2	M3 - M4 - M5 - M6 M8 - M10 - M12	-	2.5 / 3.3 / 4.2 / 5.0 6.8 / 8.5 / 10.2 mm	229,25
JMC8	-	M3 - M4 - M5 - M6 M8 - M10 - M12	-	225,59
JMC4	-	M3 - M4 - M5 - M6 M8 - M10 - M12	2.5 / 3.3 / 4.2 / 5.0 6.8 / 8.5 / 10.2 mm	256,65

TODO TERRENO

CONTENIDO

P.V.P. €

FORMA
B

TiN



35°

TiN



HSS-Co
5%

HSS-Co
5%

JMD6	M3 - M4 - M5 - M6 M8 - M10 - M12	-	-	179,11
JMD2	M3 - M4 - M5 - M6 M8 - M10 - M12	-	2.5 / 3.3 / 4.2 / 5.0 6.8 / 8.5 / 10.2 mm	210,16
JMD8	-	M3 - M4 - M5 - M6 M8 - M10 - M12	-	201,97
JMD4	-	M3 - M4 - M5 - M6 M8 - M10 - M12	2.5 / 3.3 / 4.2 / 5.0 6.8 / 8.5 / 10.2 mm	233,03

AI

CONTENIDO

P.V.P. €

DIENTE
ALTERNO

BRILLANTE

2
CANALES

BRILLANTE



HSS

HSS-Co
5%

JMAL6	M3 - M4 - M5 - M6 M8 - M10 - M12	-	-	141,81
JMAL2	M3 - M4 - M5 - M6 M8 - M10 - M12	-	2.5 / 3.3 / 4.2 / 5.0 6.8 / 8.5 / 10.2 mm	172,86
JMAL8	-	M3 - M4 - M5 - M6 M8 - M10 - M12	-	140,22
JMAL4	-	M3 - M4 - M5 - M6 M8 - M10 - M12	2.5 / 3.3 / 4.2 / 5.0 6.8 / 8.5 / 10.2 mm	171,28

MACHOS DE MÁQUINA EN ESTUCHES

USO GENERAL

CONTENIDO		P.V.P. €		
FORMA B	BRILLANTE	35°	BRILLANTE	HSS-Co 5%
PT01	M4 - M5 - M6 M8 - M10	M4 - M5 - M6 M8 - M10	108,77	



Ref. **PT01**

Plus

CONTENIDO		P.V.P. €		P.V.P. €	
FORMA B	BRILLANTE	35°	BRILLANTE	HSS PM	TiN
PT02	M4 - M5 - M6 M8 - M10	M4 - M5 - M6 M8 - M10	136,83	PT03	200,93



Ref. **PT03**

INOX

CONTENIDO		P.V.P. €		P.V.P. €	
FORMA B	OX	35°	OX	HSS PM	TiN
PT05	M4 - M5 - M6 M8 - M10	M4 - M5 - M6 M8 - M10	179,78	PT13	191,32



Ref. **PT05**



CONTENIDO		P.V.P. €		P.V.P. €	
FORMA B	OX	35°	OX	HSS V3	TINALOX
PT04	M4 - M5 - M6 M8 - M10	M4 - M5 - M6 M8 - M10	154,29	PT14	231,86



Ref. **PT04**

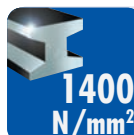

CONTENIDO		P.V.P. €		
FORMA B	TiCN	15°	TiCN	HSS PM
PT11	M4 - M5 - M6 M8 - M10	M4 - M5 - M6 M8 - M10	279,51	



Ref. **PT11**

MACHOS DE MÁQUINA EN ESTUCHES

Al



Ref. **PT06**

FUNDICIÓN



Ref. **PT07**

CONTENIDO

P.V.P. €

FORMA B



HSS-Co 5%

CONTENIDO

P.V.P. €

FORMA C

HSS-Co 5%

PT06

M4 - M5 - M6
M8 - M10

M4 - M5 - M6
M8 - M10

170,57

PT07

M4 - M5 - M6 - M8 - M10
M4 - M5 - M6 - M8 - M10

128,91

LATÓN



Ref. **PT10**



Ref. **PT08**

CONTENIDO

P.V.P. €

FORMA C

HSS-Co 5%

CONTENIDO

P.V.P. €



HSS-Co 5%

PT10

M4 - M5 - M6 - M8 - M10
M4 - M5 - M6 - M8 - M10

156,70

PT08

M4 - M5 - M6 - M8 - M10
M4 - M5 - M6 - M8 - M10

235,93



Ref. **PT09**

TOL 6G



Ref. **PT12**

CONTENIDO

P.V.P. €

BROCA MACHO

HSS-Co 5%

CONTENIDO

P.V.P. €

FORMA B



HSS-Co 5%

PT09

M4 - M5 - M6 - M8 - M10
M4 - M5 - M6 - M8 - M10

317,84

PT12

M4 - M5 - M6
M8 - M10

176,25

EXPOSITORES DE METACRILATO PARA MACHOS DE MÁQUINA

EXPOSITOR DE METACRILATO MM-03

Composición: Machos de máquina, Serie Normal

HSS-Co
5%

FORMA B	Agujeros pasantes, Ref. 2						
	M4 5	M5 10	M6 10	M8 10	M10 10	M12 5	M14 4

35°	Agujeros ciegos, Ref. 4						
	M4 5	M5 10	M6 10	M8 10	M10 10	M12 5	M14 4

Dimensiones: ancho 240 x fondo 240 x alto 245 mm

P.V.P.: 1.406,13 €



Ref. **MM-03**



Ref. **MM-04**

EXPOSITOR DE METACRILATO MM-04

Composición: Machos de máquina, Serie Plus
Fabricados en Acero sinterizado PM

HSS-Co
5%

Plus

FORMA B	Agujeros pasantes, Ref. 2						
	M4 5	M5 10	M6 10	M8 10	M10 10	M12 5	M14 4

35°	Agujeros ciegos, Ref. 4						
	M4 5	M5 10	M6 10	M8 10	M10 10	M12 5	M14 4

Dimensiones: ancho 240 x fondo 240 x alto 245 mm

P.V.P.: 1.693,57 €

EXPOSITOR DE METACRILATO MM-05

Composición: Machos de máquina para trabajos especiales

FORMA B	Agujeros pasantes, Ref. 2						
	M4 1	M5 2	M6 2	M8 2	M10 2	M12 1	M14 1

1200 N/mm²	M4	M5	M6	M8	M10	M12	M14
	1	2	2	2	2	1	1

INOX	M4	M5	M6	M8	M10	M12	M14
	1	2	2	2	2	1	1

Al	M4	M5	M6	M8	M10	M12	M14
	1	2	2	2	2	1	1

TiN	M4	M5	M6	M8	M10	M12	M14
	1	2	2	2	2	1	1

FUNDICIÓN	M4	M5	M6	M8	M10	M12	
	1	2	2	2	2	1	

35°	Agujeros ciegos, Ref. 4						
	M4 1	M5 2	M6 2	M8 2	M10 2	M12 1	M14 1

1200 N/mm²	M4	M5	M6	M8	M10	M12	M14
	1	2	2	2	2	1	1

INOX	M4	M5	M6	M8	M10	M12	M14
	1	2	2	2	2	1	1

Al	M4	M5	M6	M8	M10	M12	M14
	1	2	2	2	2	1	1

TiN	M4	M5	M6	M8	M10	M12	M14
	1	2	2	2	2	1	1

FUNDICIÓN	M4	M5	M6	M8	M10	M12	
	1	2	2	2	2	1	

Dimensiones: ancho 240 x fondo 240 x alto 245 mm

P.V.P.: 2.381,15 €

TERRAJA ROSCADORA **LEVOT** PARA ROSCAR TUBO DE ACERO O PLASTICO DE PASO MÉTRICO

CARACTERÍSTICAS:

- * Estas terrajas están pensadas para roscar las tres medidas más pequeñas de paso métrico:
- * Referencia M3-A1: para roscar a M16 x 1,50 - M20 x 1,50 - M25 x 1,50 (presentación en estuche metálico).
- * Referencia M3-A2: para roscar a M20 x 1,50 - M25 x 1,50 - M32 x 1,50 (presentación en caja de cartón).
- * Se recomienda el uso de aceite lubricante **Tap Magic** para conseguir un mejor resultado y mayor facilidad al realizar la rosca con menor esfuerzo por la reducción de coeficiente de fricción.
- * Es ideal para pequeños trabajos de electricidad.

Ref. **M3-A1**

Ref. **M3-A2**

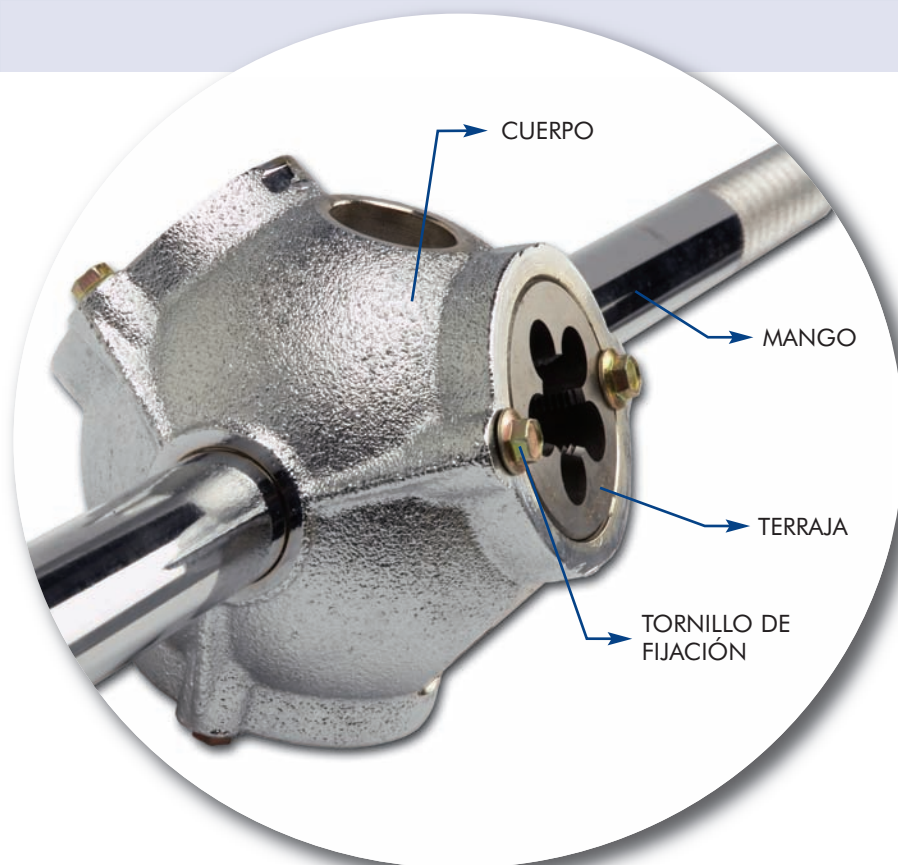

			MM3A
DESCRIPCIÓN			€
MM3A0001	Terraja completa LEVOT	Ref. M3 - A1: M16 - M20 - M25	517,43
MM3A0002	Terraja completa LEVOT	Ref. M3 - A2: M20 - M25 - M32	494,22

RECAMBIOS PARA LAS TERRAJAS ROSCADORAS

Ref. M3-A1 y M3-A2

TOL
8g

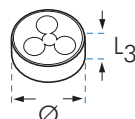

			MM
DESCRIPCIÓN			€
		Ø x L3 mm	
MM3A1101	Cuerpo mecanizado M3 - A1		234,98
MMCC0016	Cojinete LEVOT M16 x 1,50	50,5 x 16	63,11
MMCC0020	Cojinete LEVOT M20 x 1,50	50,5 x 16	66,26
MMCC0025	Cojinete LEVOT M25 x 1,50	50,5 x 16	96,08
MMCC0032	Cojinete LEVOT M32 x 1,50	50,5 x 16	129,71
MM3A1201	Mango M3 - A1 (Unidad)		50,51
MM4A1201	Mango M3 - A2 (Unidad)		54,53
MM4A1301	Tornillo de fijación (Unidad)		7,80

TERRAJA ROSCADORA **LEVOT** PARA ROSCAR TUBO DE ACERO O PLÁSTICO DE PASO MÉTRICO

CARACTERÍSTICAS:

- * Esta terraja está pensada para roscar las cuatro medidas más pequeñas y más usuales de paso métrico:
- * M16 x 1,50 - M20 x 1,50 - M25 x 1,50 - M32 x 1,50
- * Se recomienda el uso de aceite lubricante **Tap Magic** para conseguir un mejor resultado y mayor facilidad al realizar la rosca con menor esfuerzo por la reducción de coeficiente de fricción.
- * Presentación en caja de cartón.

Ref. **M4-A** (La más usual)

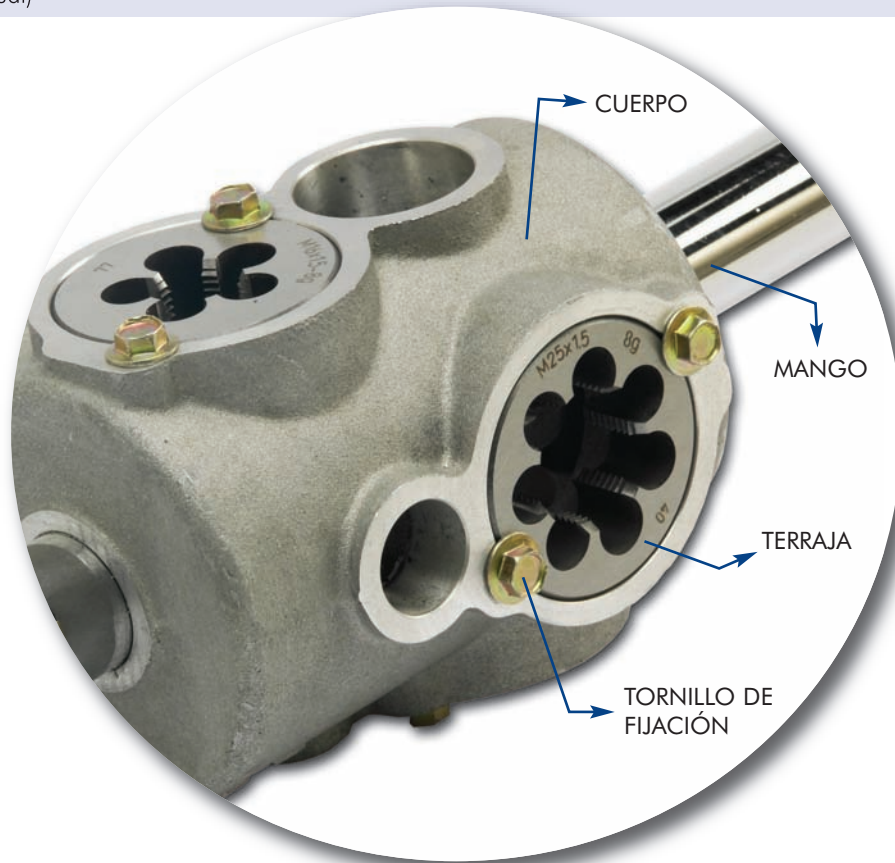

			MM4A
DESCRIPCIÓN			€
MM4A0001	Terraja completa LEVOT	Ref. M4A: M16 - M20 - M25 - M32	624,04

RECAMBIOS PARA LAS TERRAJAS ROSCADORAS

Ref. M4-A

TOL
8g

		MM
DESCRIPCIÓN		€
		Ø x L ₃ mm
MM4A1101M	Cuerpo mecanizado vacío M4A	240,65
MMCC0016	Cojinete LEVOT M16 x 1,50	50,5 x 16 63,11
MMCC0020	Cojinete LEVOT M20 x 1,50	50,5 x 16 66,26
MMCC0025	Cojinete LEVOT M25 x 1,50	50,5 x 16 96,08
MMCC0032	Cojinete LEVOT M32 x 1,50	50,5 x 16 129,71
MM4A1201	Mango M3 - A2 / M4 (Unidad)	54,53
MM4A1301	Tornillo de fijación (unidad)	7,80

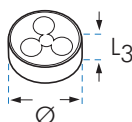

TERRAJA ROSCADORA **LEVOT** PARA ROSCAR TUBO DE ACERO O PLÁSTICO DE PASO MÉTRICO

CARACTERÍSTICAS:

- * La terraja Ref. MM3B0001, está pensada para roscar las tres medidas más grandes de paso métrico fino:
- * M40 x 1,50 - M50 x 1,50 - M63 x 1,50 Presentación en estuche de plástico reforzado.
- * Las terrajas individuales Ref. MM3B0040-MM3B0050-MM3B0063 Se presentan en cajas de cartón.
- * Se recomienda el uso de aceite lubricante **Tap Magic** para conseguir un mejor resultado y mayor facilidad al realizar la rosca con menor esfuerzo por la reducción de coeficiente de fricción.

Ref. **M3-B** (para roscar M40 - M50 y M63 x 1,50)



			MM3B
DESCRIPCIÓN			€
MM3B0001	Terraja completa LEVOT ref. M3-B: M40 - M50 - M63		1.068,26
MM3B0040	Terraja LEVOT ref. M3-B, sólo con la terraja de M40 x 1,50		399,39
MM3B0050	Terraja LEVOT ref. M3-B, sólo con la terraja de M50 x 1,50		461,36
MM3B0063	Terraja LEVOT ref. M3-B, sólo con la terraja de M63 x 1,50		505,02

RECAMBIOS PARA LAS TERRAJAS ROSCADORAS

Ref. M3-B

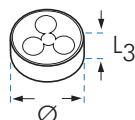

				MM
DESCRIPCIÓN				€
			Ø x L3 mm	
MMCC0040	Cojinete LEVOT M40 x 1,50		105 x 22	210,77
MMCC0050	Cojinete LEVOT M50 x 1,50		105 x 22	273,04
MMCC0063	Cojinete LEVOT M63 x 1,50		105 x 22	335,33
MM3B1201	Mango M3 - B (Unidad)			27,96
MM3B1301	Tornillo de fijación para la guía (Unidad)			1,37
MM3B1440	Guía M3-B para tubo de 40			24,22
MM3B1450	Guía M3-B para tubo de 50			25,46
MM3B1501	Tapa M3-B para la sujeción del cojinete			35,96