

PORTABROCAS Y ACCESORIOS

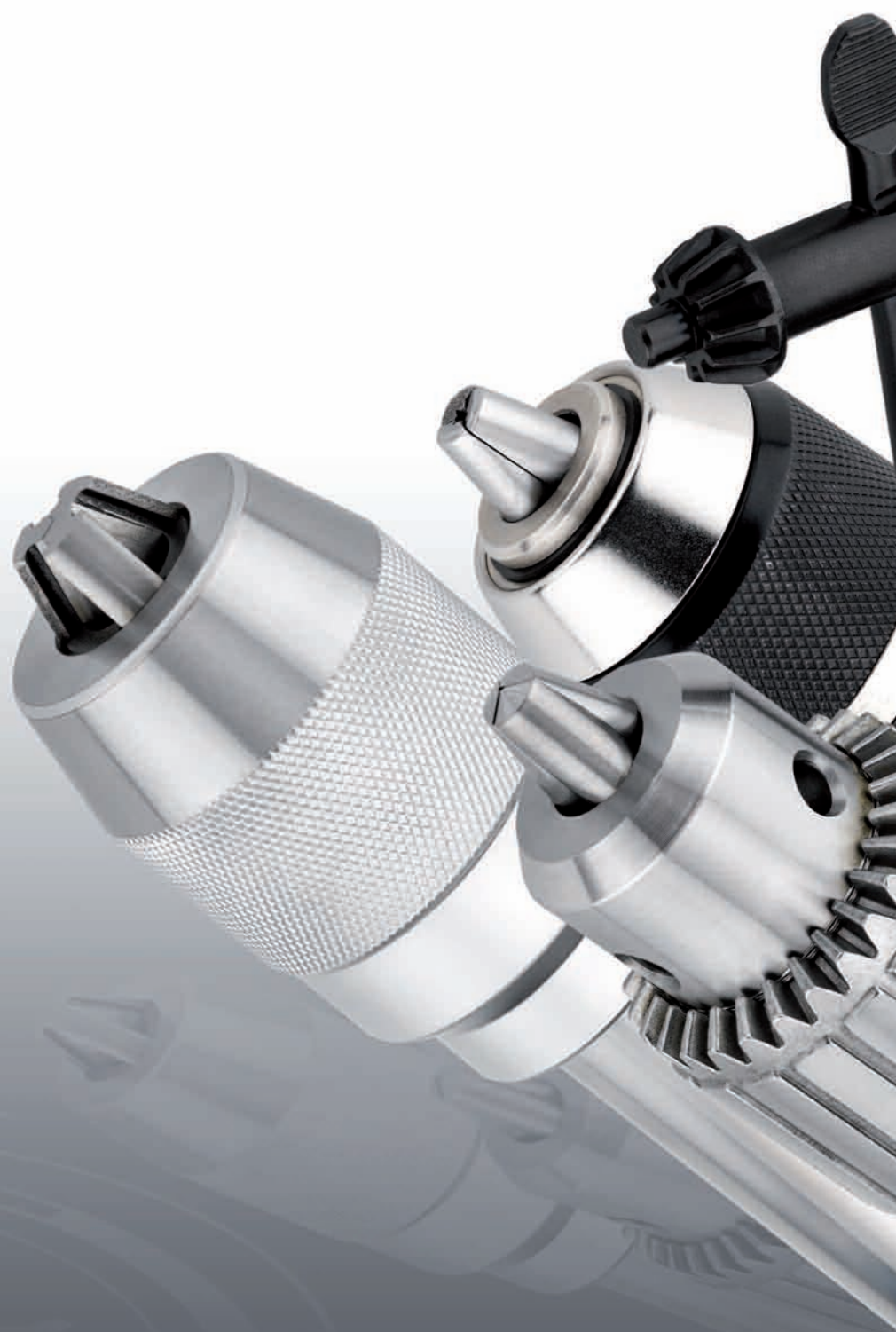

PORTABROCAS INDUSTRIALES PARA TALADROS DE COLUMNA O CNC

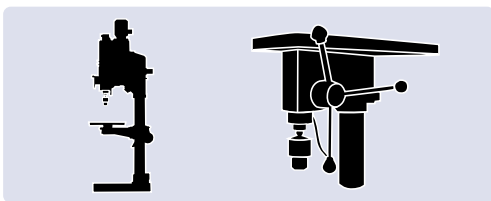

<0,05 Ref. **DC1** ALTA PRECISIÓN

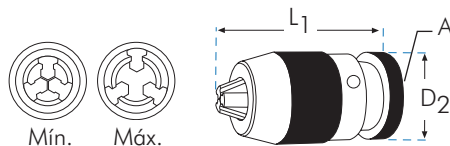

						DC1	DC1-GARRA	
	PRECISIÓN mm	Mín.-Máx. mm	A	D ₂ mm	L ₁ mm	€		€
DC1-10-B12	<0,05	1-10	B12	42,5	90,5	129,44	DC1-10-GARRA	27,67
DC1-13-B16	<0,05	1-13	B16	48,5	104	138,49	DC1-13-GARRA	27,67
DC1-16-B16	<0,05	1-16	B16	53	119	147,47	DC1-16-GARRA	27,67
DC1-16-B18	<0,05	1-16	B18	53	119	147,47	DC1-16-GARRA	27,67
DC1-20-B22	<0,05	5-20	B22	58	130	169,69	DC1-20-GARRA	27,67

<0,12 Ref. **DC2** INDUSTRIAL

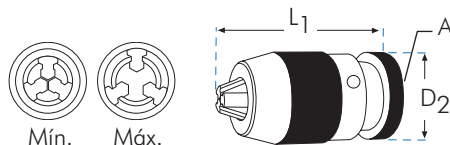

						DC2	DC1-GARRA	
	PRECISIÓN mm	Mín.-Máx. mm	A	D ₂ mm	L ₁ mm	€		€
DC2-13-1/2	<0,12	1-13	1/2-20 UNF	48,5	104	102,22	DC1-10-GARRA	27,67
DC2-13-B16	<0,12	1-13	B16	48,5	104	102,22	DC1-13-GARRA	27,67
DC2-16-B16	<0,12	1-16	B16	53	119	125,11	DC1-16-GARRA	27,67
DC2-16-B18	<0,12	1-16	B18	53	119	125,11	DC1-16-GARRA	27,67
DC2-20-B22	<0,12	5-20	B22	58	130	135,75	DC1-20-GARRA	27,67

<0,20 Ref. **DC3** INDUSTRIAL LIGERO

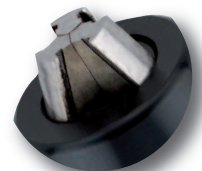
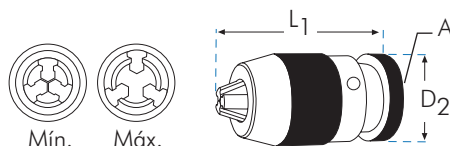

						DC3	DC1-GARRA	
	PRECISIÓN mm	Mín.-Máx. mm	A	D ₂ mm	L ₁ mm	€		€
DC3-10-3/8	<0,20	1-10	3/8-24 UNF	34	75,5	66,67	DC1-10-GARRA	27,67
DC3-10-1/2	<0,20	1-10	1/2-20 UNF	34	75,5	66,67	DC1-10-GARRA	27,67
DC3-13-B16	<0,20	1-13	B16	43	94,5	69,34	DC1-13-GARRA	27,67
DC3-13-3/8	<0,20	1-13	3/8-24 UNF	43	94,5	69,34	DC1-13-GARRA	27,67
DC3-13-1/2	<0,20	1-13	1/2-20 UNF	43	94,5	69,34	DC1-13-GARRA	27,67
DC3-16-B18	<0,20	1-16	B18	48	119,5	105,11	DC1-16-GARRA	27,67
DC3-16-1/2	<0,20	1-16	1/2-20 UNF	48	105	105,11	DC1-16-GARRA	27,67
DC3-16-5/8	<0,20	1-16	5/8-18 UNF	48	105	105,11	DC1-16-GARRA	27,67

PORTABROCAS INDUSTRIALES CON MANGO CÓNICO PARA TALADROS DE COLUMNA O CNC

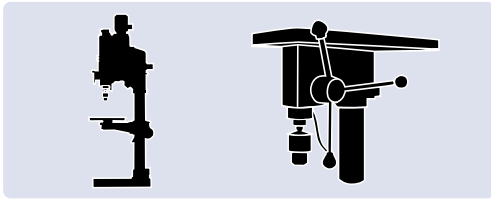

<0,05

Ref. **DC10**

ALTA PRECISIÓN

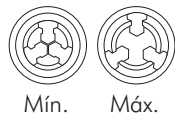

Mín. Máx.

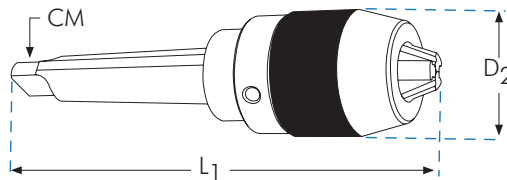

						DC10	DC1-GARRA	
	PRECISIÓN mm	Mín.-Máx. mm	CM	D ₂ mm	L ₁ mm	€		€
DC10-13-CM2	<0,05	1-13	CM2	51	174	210,89	DC1-13-GARRA	27,67
DC10-13-CM3	<0,05	1-13	CM3	51	192,5	213,45	DC1-13-GARRA	27,67
DC10-13-CM4	<0,05	1-13	CM4	51	218,5	215,52	DC1-13-GARRA	27,67
DC10-16-CM3	<0,05	1-16	CM3	56,5	207	218,24	DC1-16-GARRA	27,67
DC10-16-CM4	<0,05	1-16	CM4	56,5	232	222,20	DC1-16-GARRA	27,67

<0,12

Ref. **DC11**

INDUSTRIAL

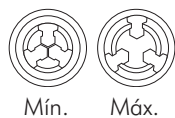

Mín. Máx.

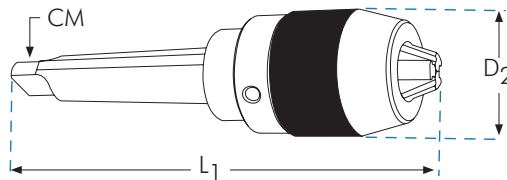

						DC11	DC1-GARRA	
	PRECISIÓN mm	Mín.-Máx. mm	CM	D ₂ mm	L ₁ mm	€		€
DC11-13-CM2	<0,12	1-13	CM2	51	174	128,89	DC1-13-GARRA	27,67
DC11-13-CM3	<0,12	1-13	CM3	51	192,5	128,89	DC1-13-GARRA	27,67
DC11-13-CM4	<0,12	1-13	CM4	51	218,5	128,89	DC1-13-GARRA	27,67
DC11-16-CM3	<0,12	1-16	CM3	56,5	207	151,11	DC1-16-GARRA	27,67
DC11-16-CM4	<0,12	1-16	CM4	56,5	232	151,11	DC1-16-GARRA	27,67

PORTABROCAS PROFESIONALES AUTOMÁTICOS

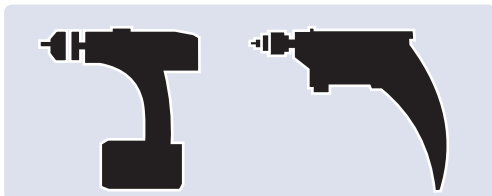

<950W

Ref. DC4



- Bloqueo automático.
- Cuerpo de plástico.
- Taladro tanto en modo rotación como en percusión.

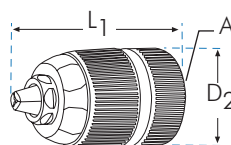

	W	Mín.-Máx. mm	A	D ₂ mm	L ₁ mm	DC4 €	DC4-GARRA €
DC4-10-3/8	<950	1-10	3/8-24 UNF	41	65	40,00	DC4-10-GARRA 8,30
DC4-10-1/2	<950	1-10	1/2-20 UNF	41	65	40,00	DC4-10-GARRA 8,30
DC4-13-3/8	<950	2-13	3/8-24 UNF	43	75	53,33	DC4-13-GARRA 8,30
DC4-13-3/8-SDS	<950	2-13	3/8-24 UNF	43	75	61,53	DC4-13-GARRA 8,30
DC4-13-1/2	<950	2-13	1/2-20 UNF	43	75	53,33	DC4-13-GARRA 8,30
DC4-13-1/2-SDS	<950	2-13	1/2-20 UNF	43	75	61,53	DC4-13-GARRA 8,30

<1050W

Ref. DC5



- Bloqueo automático.
- Cuerpo de metal.
- Alta potencia.
- Garras especiales para alto rendimiento.
- Taladro tanto en modo rotación como en percusión.

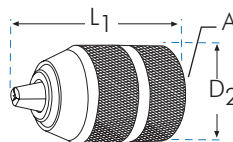

	W	Mín.-Máx. mm	A	D ₂ mm	L ₁ mm	DC5 €	DC4-GARRA €
DC5-10-3/8	<1050	1-10	3/8-24 UNF	41	64,5	41,40	DC4-10-GARRA 8,30
DC5-13-3/8	<1050	2-13	3/8-24 UNF	43	75	57,78	DC4-13-GARRA 8,30
DC5-13-1/2	<1050	2-13	1/2-20 UNF	43	75	57,78	DC4-13-GARRA 8,30
DC5-13-SDS	<1050	2-13	1/2-20 UNF	43	75	69,99	DC4-13-GARRA 8,30

PORTABROCAS DE LLAVE PROFESIONALES

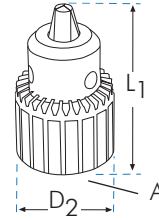
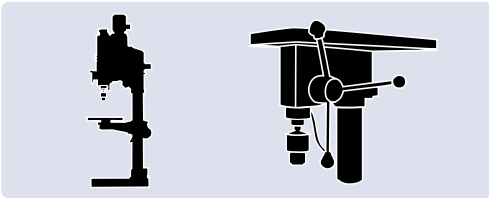

Ref. **DC6**

- Admite percusión, se recomienda uso en modo rotación.
- Incluye llave



	Mín.-Máx. mm	A	D ₂ mm	L ₁ mm	DC6		DC6-GARRA	
					€	€		
DC6-06-B10	0,6-6	B10	31,5	50,5	36,89	DC6-06-GARRA	8,30	
DC6-06-3/8	0,6-6	3/8-24 UNF	31,5	50,5	36,89	DC6-06-GARRA	8,30	
DC6-10-B12	1-10	B12	37	60	28,89	DC6-10-GARRA	8,30	
DC6-10-3/8	1-10	3/8-24 UNF	37	60	28,89	DC6-10-GARRA	8,30	
DC6-10-1/2	1-10	1/2-20 UNF	37	60	28,89	DC6-10-GARRA	8,30	
DC6-13-B12	1-13	B12	46	78	37,78	DC6-13-GARRA	8,30	
DC6-13-B16	1-13	B16	46	78	37,78	DC6-13-GARRA	8,30	
DC6-13-3/8	1-13	3/8-24 UNF	46	78	37,78	DC6-13-GARRA	8,30	
DC6-13-1/2	1-13	1/2-20 UNF	46	78	37,78	DC6-13-GARRA	8,30	
DC6-16-B16	1-16	B16	57	95	42,22	DC6-16-GARRA	13,83	
DC6-16-B18	1-16	B18	57	95	42,22	DC6-16-GARRA	13,83	
DC6-16-1/2	1-16	1/2-20 UNF	57	95	42,22	DC6-16-GARRA	13,83	
DC6-16-5/8	1-16	5/8-16 UNF	57	95	44,44	DC6-16-GARRA	13,83	
DC6-19-B22	1-19	B22	68	115	57,78	DC6-20-GARRA	13,83	

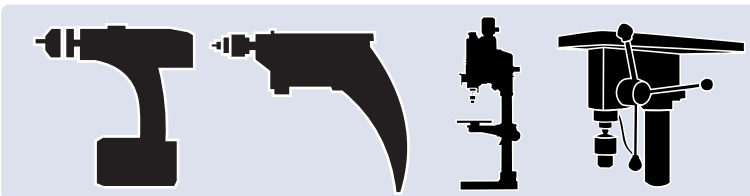

LIGERO

Ref. **DC7**

- Taladro tanto en modo percusión como en rotación.
- Incluye llave

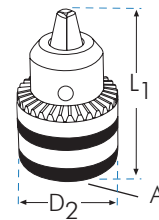

	Mín.-Máx. mm	A	D ₂ mm	L ₁ mm	DC7		DC6-GARRA	
					€	€		
DC7-06-B10	0,6-6	B10	30	50,5	18,18	DC6-06-GARRA	8,30	
DC7-06-3/8	0,6-6	3/8-24 UNF	30	50,5	18,18	DC6-06-GARRA	8,30	
DC7-10-3/8	1,5-10	3/8-24 UNF	33,5	59	17,78	DC6-10-GARRA	8,30	
DC7-10-1/2	1,5-10	1/2-20 UNF	33,5	59	17,78	DC6-10-GARRA	8,30	
DC7-13-B12	1,5-13	B12	42	70,5	21,11	DC6-13-GARRA	8,30	
DC7-13-B16	1,5-13	B16	42	70,5	21,11	DC6-13-GARRA	8,30	
DC7-13-3/8	1,5-13	3/8-24 UNF	42	70,5	21,11	DC6-13-GARRA	8,30	
DC7-13-1/2	1,5-13	1/2-20 UNF	42	70,5	21,11	DC6-13-GARRA	8,30	
DC7-13-SDS	1,5-13	1/2-20 UNF	42	70,5	22,22	DC6-13-GARRA	8,30	
DC7-16-B16	3-16	B16	51	87	26,67	DC6-16-GARRA	13,83	
DC7-16-1/2	3-16	1/2-20 UNF	51	87	26,67	DC6-16-GARRA	13,83	
DC7-16-5/8	3-16	5/8-16 UNF	51	87	26,67	DC6-16-GARRA	13,83	

• Llaves de repuesto para portabrocas consultar página siguiente

MINI-PORTABROCAS

MINI-PORTABROCAS MANUAL



P27

Incluye 2 Pinzas reversibles:

- De 0,5 a 1,5 mm
- De 0 a 3 mm

P.V.P. **8,42 €**

MINI-PORTABROCAS DE MÁQUINA



P28

Incluye 3 Pinzas:

- De 0,1 a 1 mm
- De 1,5 a 2 mm
- De 0,5 a 1,5 mm

P.V.P. **12,62 €**

ACCESORIOS PARA BROCAS Y PORTABROCAS

LLAVES PARA PORTABROCAS

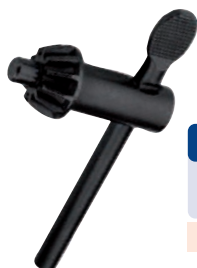

	Mín.-Máx. mm	DC €
DC-10	1 - 10	3,10
DC-13	1 - 13	3,69
DC-16	1 - 16	4,58
DC-20	5 - 20	8,12

ADAPTADORES SDS PLUS

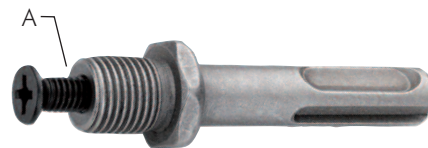

	Mín.-Máx. mm	DC €
DC-3/8	3/8 - 24 UNF	18,50
DC-1/2	1/2 - 20 UNF	18,50

ESPIGAS DE SUJECIÓN CON MANGO CÓNICO PARA PORTABROCAS

DIN 228

CONO MORSE

DIN 238

PORTA BROCAS

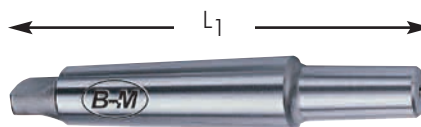

CM	PORTA BROCAS	L ₁ mm	CM €
1	B10	86	9,33
1	B12	89	7,02
1	B16	99	7,02
1	B18	107	7,02
2	B10	105	11,16
2	B12	106	8,52
2	B16	112	8,52
2	B18	119	8,52
2	B22	130	14,67
3	B12	127	14,72
3	B16	134	10,38

CM	PORTA BROCAS	L ₁ mm	CM €
3	B18	140	10,38
3	B22	147	17,49
3	B24	157	22,50
4	B16	158	15,61
4	B18	166	16,04
4	B22	176	28,83
4	B24	186	29,16
5	B16	193	63,34
5	B18	200	63,34
5	B22	208	58,99
5	B24	221	64,09
6	B22	240	120,50

ACCESORIOS PARA BROCAS

CONOS AUMENTADORES

DIN
2187

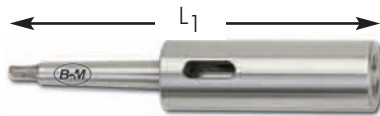

CONO MORSE			CA
EXT.	INT.	L ₁ mm	€
1	2	160	33,43
2	3	196	45,45
3	4	240	76,65
4	5	300	128,66
5	6	415	379,63

CONOS REDUCTORES

DIN
E-2185

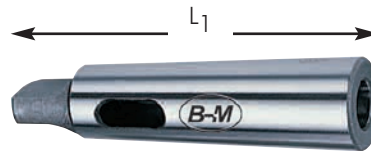

CONO MORSE			CR
EXT.	INT.	L ₁ mm	€
2	1	92	17,20
3	1	99	23,14
3	2	112	23,59
4	1	124	33,01
4	2	124	31,01
4	3	140	31,01

CONO MORSE			CR
EXT.	INT.	L ₁ mm	€
5	1	156	56,81
5	2	156	51,85
5	3	156	51,85
5	4	171	58,30
6	3	218	100,72
6	4	218	114,29
6	5	218	114,29

CONOS ALARGADORES



CONO MORSE			CA
EXT.	INT.	L ₁ mm	€
1	1	145	21,58
2	2	175	31,38
3	3	215	47,53
4	4	265	76,65
5	5	335	165,40
6	6	470	379,63

CONOS REDUCTORES ALARGADORES

DIN
E-2185



CONO MORSE			CA
EXT.	INT.	L ₁ mm	€
2	1	160	21,58
3	1	175	31,38
3	2	194	32,40
4	1	200	45,45
4	2	215	44,42
4	3	240	46,48

CONO MORSE			CA
EXT.	INT.	L ₁ mm	€
5	1	232	110,40
5	2	247	100,36
5	3	268	88,44
5	4	300	99,97
6	3	330	220,14
6	4	355	220,14
6	5	390	221,76

CUÑA EXPULSORA

DIN
317



VÁLIDOS			CE
Nº	CM	L ₁ mm	€
0	0	90	9,58
1	1 / 2	140	11,32
3	3	190	14,94
4	4	225	20,32
5	5 / 6	265	33,01

ESPIGAS DE SUJECIÓN CON MANGO CÓNICO PARA PORTABROCAS ROSCADOS

DIN
E-2185



		CM	A	CMR
				€
CMR1-3/8	1	3/8-24h	14,13	
CMR1-1/2	1	1/2-20h	14,13	
CMR2-3/8	2	3/8-24h	14,13	
CMR2-1/2	2	1/2-20h	14,13	

		CM	A	CMR
				€
CMR2-5/8	2	5/8-18h	14,13	
CMR3-3/8	3	3/8-24h	19,12	
CMR3-1/2	3	1/2-20h	19,12	
CMR3-5/8	3	5/8-18h	19,12	

ACCESORIOS PARA BROCAS

CASQUILLOS RECTIFICADORES PARA CONOS MORSE



	Ø mm		CRM	€
	EXT.	INT.		
CRCM1x20	20	1		27,44
CRCM2x25	25	2		43,12
CRCM3x32	32	3		60,48
CRCM3x40	40	3		64,96
CRCM4x40	40	4		73,36
CRCM4x50	50	4		79,52

CONTRAPUNTOS FIJOS PARA TORNOS

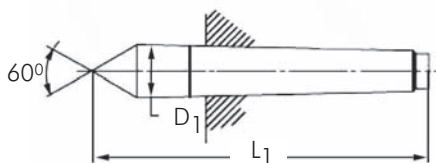

	D1 mm		L1 mm	CM	CPC	€	MD	CPC..MD	€
CPCM1	12,2	80	1			10,37			
CPCM2	18,0	100	2			13,80	CPCM2-MD	39,66	
CPCM3	24,1	125	3			21,45	CPCM3-MD	54,13	
CPCM4	31,6	160	4			33,49	CPCM4-MD	66,01	
CPCM5	44,7	200	5			47,32	CPCM5-MD	112,23	
CPCM6	63,8	270	6			182,46			

PUNTO GIRATORIO

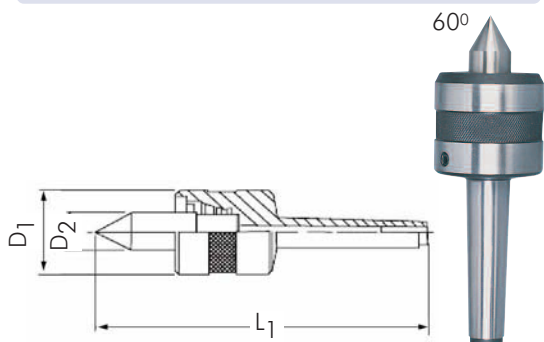

PUNTO GIRATORIO PARA TUBOS

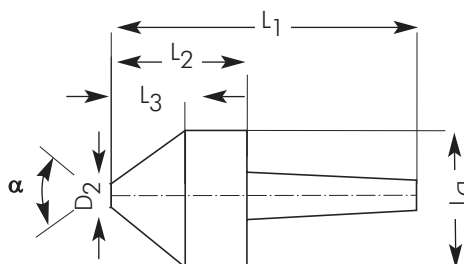

	D1 mm	D2 mm	L1 mm	CM	PGC	€
PGCM1	34	18	120	1		99,35
PGCM2	50	21	148	2		110,81
PGCM3	60	24	185	3		148,96
PGCM4	63	28	220	4		176,55
PGCM5	75	36	260	5		255,17

	D1 mm	D2 mm	L1 mm	L2 mm	L3 mm	α	CM	PGTC	€
PGTCM2	63	11,7	136	63	36	70°	2		134,40
PGTCM3	78	18,0	172	77	42	70°	3		172,67
PGTCM4	128	35,0	193	78	62	75°	4		270,67

PUNTO GIRATORIO CON SIETE PUNTAS INTERCAMBIABLES

Ref: PGICM2



CM	PGICM	€	DIMENSIONES	PGIC	€
PGICM2	2	215,08	PGIC1 31,5 x 60°		12,98
PGICM3	3	252,18	PGIC2 HEMBRA		9,27
			PGIC3 7 x 60°		9,27
			PGIC4 9 x 60°		9,27
			PGIC5 13,5 x 60°		9,27
			PGIC6 5,5 x 60°		9,27



AFILADORAS PARA BROCAS DRILL DOCTOR

750X
Alta
precisión

500X
Afilado
profesional

360X
Práctico y
económico

AFB1	AFB2	AFB3
CAPACIDAD AFILADO: \emptyset 2,5-19	CAPACIDAD AFILADO: \emptyset 2,5-13	CAPACIDAD AFILADO: \emptyset 2,5-13
ÁNGULOS DE PUNTA: 118° 135°	ÁNGULOS DE PUNTA: 118° 135°	ÁNGULOS DE PUNTA: 118°
TIPOS DE AFILADOS:	TIPOS DE AFILADOS:	TIPOS DE AFILADOS:
REAFILA BROCAS: HSS HSS-Co MD TiN	REAFILA BROCAS: HSS HSS-Co MD TiN	REAFILA BROCAS: HSS HSS-Co MD TiN
362,78 €	291,67 €	140,56 €

PORTABROCAS PARA AFILADORAS

Para 750X	Para 500X	Para 360X	Para Brocas a izquierdas
AFB1PB	AFB2PB	AFB3PB	AFB2PBI
56,11 €	56,13 €	93,89 €	56,13 €

MUELA DE GRANO STANDARD PARA AFILADORAS 750X, 500X Y 350X

MUELA FINO STANDARD PARA AFILADORAS 750X, 500X Y 350X



AFBT
55,56 €



AFBR
55,56 €

TORNILLOS PARA AFILADORAS 750X Y 500X

MALETÍN VACÍO PARA AFILADORAS 750X, 500X Y 350X



AFBTLL
6,36 €



MALETIN
26,67 €

AFILADORAS PARA HERRAMIENTAS DE CARPINTERÍA WORK SHARP

AFB4

Motor de 150 Watts de potencia con 580 R.P.M. de velocidad de giro. Afilado manual fácil y preciso. Sistema de disipación de calor mediante chorro de aire que refrigera las herramientas sin el sucio sistema de mojado.

Contenido

1. Afiladora para herramientas de carpintería WORK SHARP 3000.
2. 2 Ruedas de vidrio templado Ref. AFB4M2.
3. 1 Rueda Edge-Vision Ref. AFB4M3.
4. 3 Abrasivos grano grueso de 150 mm Ref. AFB4M4. (2) Ref. P120 / (1) Ref. P400.
5. 8 Abrasivos grano fino de 150 mm Ref. AFB4M5. (4) Ref. P400 / (4) Ref. P1000.
6. 1 Abrasivo "mullido" para afilar extra fino. Ref. AFB4M6. (1) Ref.3600 Micro-Mesh.
7. 5 Abrasivos para rueda Edge-Vision Ref. AFB4M7. (1) Ref.P80 / (2) Ref.P400 / (2) Ref.P1200
8. Barra de crep.
9. Soporte superior.
10. Perilla superior.

595,68 €

Serie 3000
Afilado rápido y fácil de formones, cuchillas, punteros y cinceles



ACCESORIOS Y RECAMBIOS PARA AFILADORA WORK SHARP 3000

DISCOS ABRASIVOS GRANO GRUESO

Para la rueda de vidrio templado AFB4M2

- 2 u. Óxido cerámico P80, Ø150 mm
- 2 u. Óxido cerámico P120, Ø150 mm
- 3 u. Óxido de aluminio P220, Ø150 mm
- 2 u. Óxido cerámico P400, 15,08cm²

AFB4M4

31,83 €

POSTIZO PARA AFILADO 75 mm

Para soporte de la herramienta en el afilado

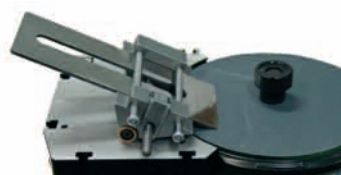

AFB4WB

148,83 €

DISCOS ABRASIVOS GRANO FINO

Para la rueda de vidrio templado AFB4M2

- 4 u. Óxido de aluminio P400, Ø150 mm
- 6 u. Óxido de aluminio P1000, Ø150 mm
- 2 u. Abrasivo de recubrimiento P1500, 15,08cm²

AFB4M5

31,83 €

DISCO ABRASIVO DE CUERO (1 u.)

Para acabados pulidos a espejo



AFB4M1

63,75 €

DISCOS ABRASIVOS EXTRA FINOS

Para la rueda de vidrio templado AFB4M2

- 1 u. 3600 Micro-Mesh (6 µ micron), Ø150 mm
- 1 u. 6000 Micro-Mesh (2 µ micron), Ø150 mm

AFB4M6

31,83 €

RUEDA DE VIDRIO TEMPLADO (1 u.)

Soporte para disco abrasivos AFB4M4-M6-M5



AFB4M2

42,47 €

DISCOS ACANALADOS EDGE VISION

Para la rueda acanalada AFB4M3

- 1 u. Abrasivo acanalado P80, Ø150 mm
- 2 u. Abrasivo acanalado P400, Ø150 mm
- 2 u. Abrasivo acanalado P1200, Ø150 mm
- 1 u. 6000 Micro-Mesh acanalado (2 µ micron), Ø150 mm

AFB4M7

31,83 €

RUEDA ACANALADA EDGE-VISION (1 u.)

Permite ver el filo de la cuchilla cuando afila



AFB4M3

42,47 €